

Specialist in  
verspanende  
gereedschappen

**RMS**  
**TOOLS**

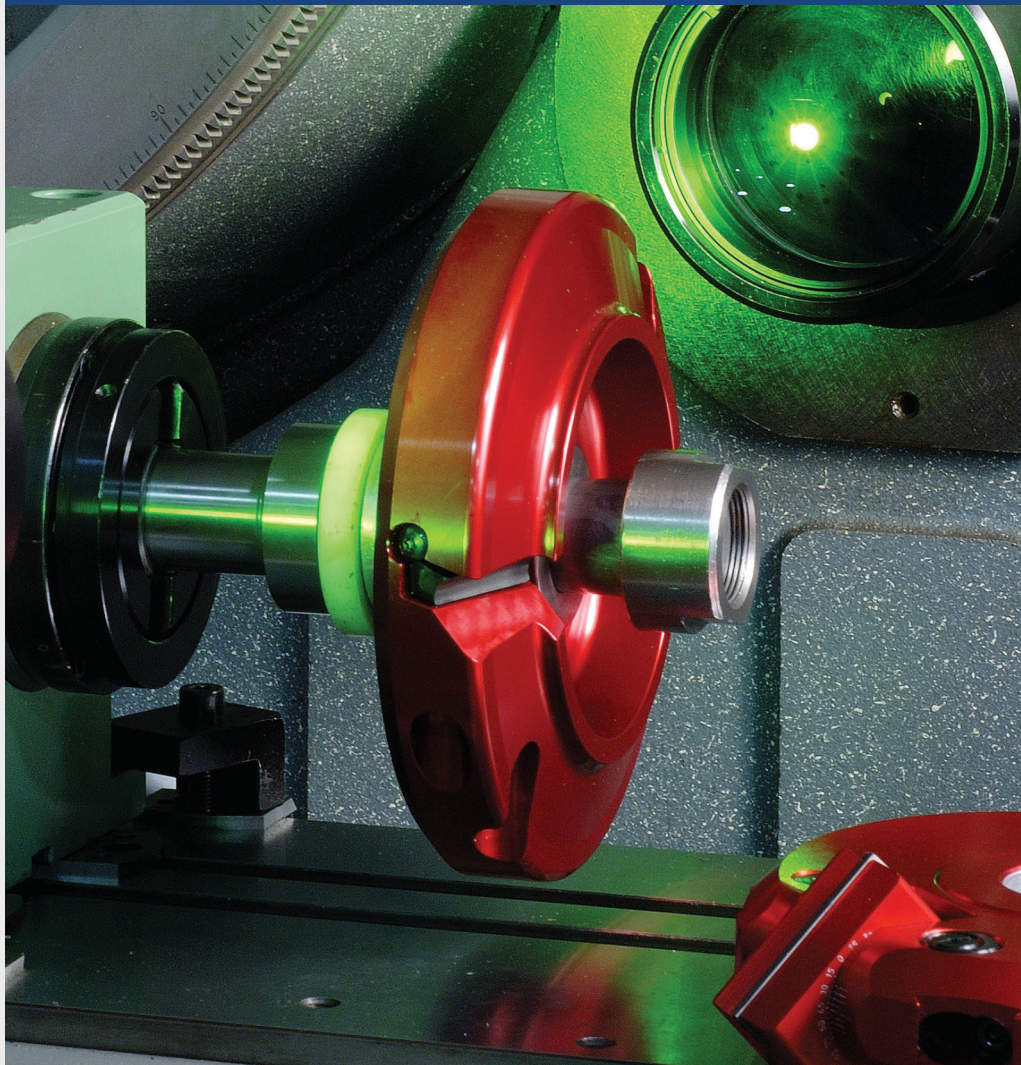

**Frezen**

Freeskoppen en freesmessen  
voor stationaire freesmachines. In HM, HSS of SP  
voor de veeleisende professional

**Catalogus**

**2**

# Freeskoppen

## Freeskoppencatalogus RvS tools

Voor u ligt de nieuwe freeskoppencatalogus van RvS Tools. Alle freeskoppen die hierin zijn opgenomen zijn bij ons op voorraad, tenzij apart vermeld.

### **Veel freesplezier namens het team van RvS Tools!**

Voor de Universeelkoppen zijn de universeelmessen op voorraad in SP-staal. Voor een aantal zijn ook uitvoeringen in HSS en/of HM op voorraad. Andere typen op bestelling.

Van de andere freeskoppen zijn er veelal uitvoeringen met HM wisselmessen en een aantal nog met vaste HM messen. De keuze hiertussen wordt vooral bepaald door de gebruiksintensiteit.

Indien u toch niet in deze catalogus de gewenste freeskop kunt vinden, **neem dan contact met ons op**. Wij leveren u graag andere typen op aanvraag!

Wij leveren **freeskoppen in aluminium en stalen uitvoering**.

De levensduur van freeskoppen voor hout en houtachtige materialen is afhankelijk van de behandeling door zowel de gebruiker als de vakhandel. Freesmessen hebben een uiterst scherpe en gevoelige snijkant, lees daarom, voor u aan de slag gaat, eerst de adviezen voor gebruik op op pagina 6.

**Veel succes!**

RvS Tools B.V.  
Meridiaan 53  
2801 DA Gouda  
Tel.: 0182 338 444



Catalogus 2021  
Wijzigingen voorbehouden  
©RvS Tools B.V.  
[info@rvsnl.com](mailto:info@rvsnl.com)  
[www.rvstools.eu](http://www.rvstools.eu)











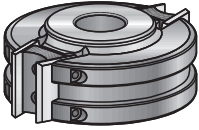
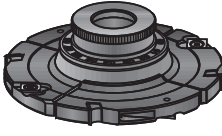
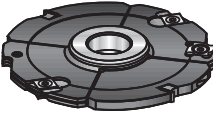

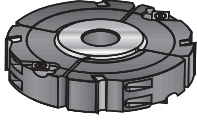
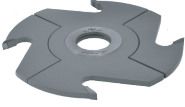

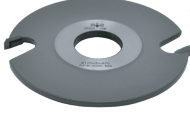
Nadruk verboden

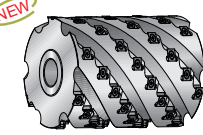
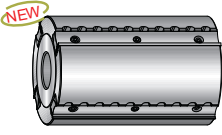
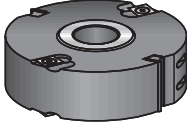
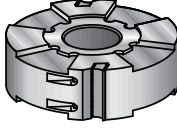
# Freeskoppen

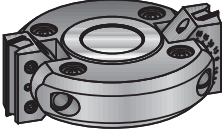
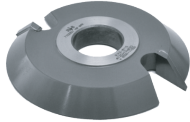
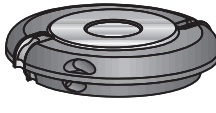
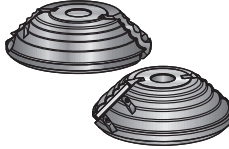
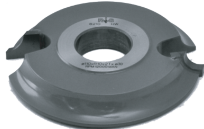
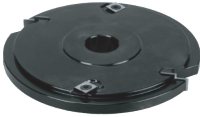
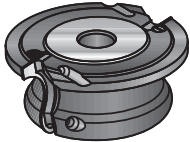
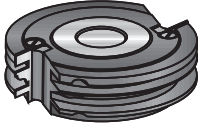
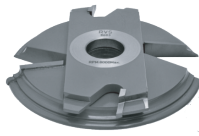
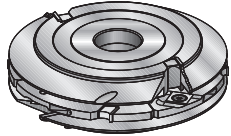
## Inhoudsopgave

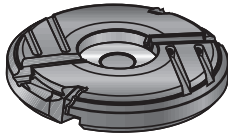
<b>Introductie</b>	<b>3</b>
<b>Inhoudsopgave</b>	<b>4</b>
<b>Freeskoppenselector</b>	<b>5</b>
<b>Freesmessenselector universeelmessen</b>	<b>7</b>
<b>Algemene gebruiksaanwijzing</b>	<b>8</b>
<b>Universeelkoppen</b>	<b>9</b>
<b>Groeffrezen</b>	<b>13</b>
<b>Groefzagen</b>	<b>18</b>
<b>Lamellofrezen</b>	<b>19</b>
<b>Schaafkoppen</b>	<b>20</b>
<b>Sponningkoppen</b>	<b>21</b>
<b>Verlijmkoppen</b>	<b>22</b>
<b>Afschuinen en kanten</b>	<b>24</b>
<b>Hol/Bol (Concaaf/Convex) koppen</b>	<b>26</b>
<b>Profielkoppen</b>	<b>28</b>
<b>Bossingkoppen</b>	<b>33</b>
<b>Freetskoppensets</b>	<b>39</b>
<b>Kisten voor freeskoppen</b>	<b>41</b>
<b>Kopieerringensets</b>	<b>42</b>
<b>Uitvulringenset</b>	<b>42</b>
<b>Verloopringenset</b>	<b>42</b>
<b>Universeelmessenselector</b>	<b>44</b>
<b>Universeelmessen 40x4</b>	<b>45</b>
<b>Universeelmessen 50x4</b>	<b>55</b>
<b>Universeelmessen 50x5,5</b>	<b>60</b>
<b>Universeelmessen 60x5,5</b>	<b>63</b>
<b>Universeelbossingmessen 50x4</b>	<b>64</b>
<b>Universeelmessen 59x64</b>	<b>65</b>
<b>Universeel blanketten</b>	<b>67</b>

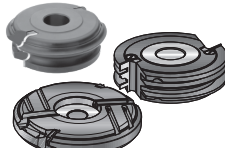
# Freeskoppen

				
Universeelkoppen	Variabele groeffrezen HM wisselmessen met klok	Variabele groeffrezen HM wisselmessen	Uitbreidingsringen voor variabele groeffrezen HM wisselmessen	Variabele groeffrezen HM wisselmessen
9-12	13	13-14	14	15
				
Variabele groeffrezen HM vaste messen	Groeffrezen HM wisselmessen	Groeffrezen HM vaste messen	Groeffzagen HM vaste messen	Lamello frezen
16	17	17	18	19
				
Vlankbankkoppen ruw HM wisselmessen	Vlankbankkoppen fijn HM wisselmessen	Sponningkop HM wisselmessen	Stapelbare sponningkop HM wisselmessen	Diverse verlijmfrezen HM wisselmessen
20	20	21	21	22-23
				
Diverse zwenkmeskoppen HM wisselmessen	45 graden freeskop HM vaste messen	Convex/Concaaf koppen HM wisselmessen	Convex/Concaaf koppen HM wisselmessen	Convex/bol kop HM vaste messen
24-25	25	26	27	27
				
Freeskop driepuntssluiting HM wisselmessen	Freeskop trapleuning HM wisselmessen	Profiel/Contraprofiel freeskop HM wisselmessen	Profiel/Contraprofiel freeskop HM vaste messen	Profiel/Contraprofiel freeset HM wisselmessen
28	28	29	29	30
				
Profielfreeskop HM wisselmessen	Bossingprofiel freeskoppen HM wisselmessen	Uni-bossingprofielfreeskop met wisselmessen	Paneeldeurset van drie freeskoppen met HM wisselmessen	5 delige Multiprofiel Set
32	33-37	38	39	41

# Freeskoppen

## Toelichting

---

### I – Freesmessen

#### Messen:

Vaste messen van HM. Hardmetalen messen gesoldeerd op de freeskop

Wisselmessen universeelkoppen

- **SP** voor zachtere houtsoorten
- **HSS** voor slijtende materialen en intensief gebruik
- **HM** Hard metaal voor zeer slijtende materialen en zeer intensief gebruik

Wisselmessen bij overige freeskoppen zijn allen van HM geklemd of geschroefd op de kop.

---

### II – Type bediening

**MAN** geschikt voor handmatige aanvoer

**MEC** alleen geschikt voor machinale aanvoer

---

### III – Basisinfo

#### As d

*Diameters*

Metrisch: standaard op 30mm; een aantal op 40mm. Rest op aanvraag.

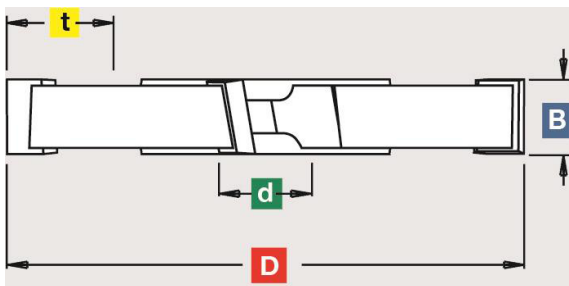

#### Maten (dimensies)

*De belangrijkste:*

- d - asmaat
- D - diameter – freesdeel
- B - snijhoogte
- a - snijhoek
- R - radius
- T - snijdiepte
- Z - aantal messen
- V - aantal voorsnijders
- P - parts

rpm maximum toerental

**U** = Uitlopend

**P** = Parts/Onderdelen

# Freeskoppen

## Groeffrezen

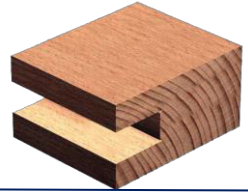

## Lamello frezen



## Sponningkoppen

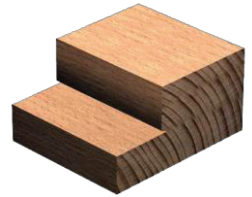

## Lijmverbindingen

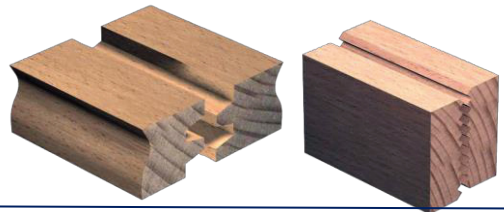

## Afrondfreeskoppen hol en bol

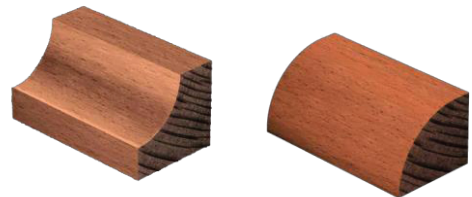

## Afschuinkoppen en Zwenkmeskoppen



## Driepuntssluitingen

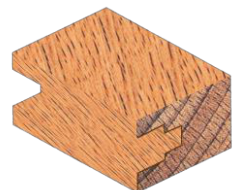

## Trapleuningfrezen

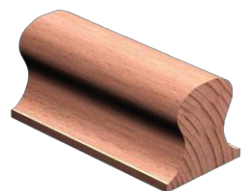

# Freeskoppen

## Freeskoppen en frezen met verwisselbare messen:

Bij het wisselen van de messen moet u zeer voorzichtig zijn. Handel volgens onderstaande instructies:

- Let op dat de stroom uitgeschakeld is van de machine.
- Gebruik de originele sleutel, geleverd bij het gereedschap, om de schroeven los te draaien. In geen geval een hamer, hefboom of dergelijke gebruiken. Deze kunnen ernstige schade veroorzaken aan het bevestigingssysteem.
- Verwijder spanblok, spanschroeven en messen.
- Reinig spanblok, mes en mes-zitting grondig.
- Plaats messen en eventuele voorsnijders in de juiste (snij)positie. Controleer het geheel nogmaals.
- Draai de bevestigingsschroef van mes en voorsnijders met bijgeleverde sleutel goed aan. Let op of de messen in de goede richting gemonteerd zijn.

## Veiligheidsvoorschriften:

Lees voor het gebruik deze aanwijzingen en volg ze nauwkeurig op:

- Let op dat de snijkanten niet worden beschadigd bij het verplaatsen, monteren en demonteren.
- Gebruik uitsluitend originele messen, voorsnijders en spanblokken.
- Check periodiek de speling van de as van de freesmachine (0.02 maximum circulair en 0.01mm zijdelings).
- Bewaar elke freeskop apart. Freeskoppen nooit stapelen of met de scherpe delen op een metalen oppervlak plaatsen.
- Verzekert u zich ervan dat het gereedschap juist is bevestigd en niet kan bewegen; correct is bevestigd op de as; de freesmessen vrijlopen van b.v. aanslag of beschermkap.
- De as van uw machine moet een glad oppervlak hebben. Het is niet toegestaan andere dan geslepen tussenringen te gebruiken.
- Het is verstandig uw handen met handschoenen te beschermen.
- Werk altijd met het juiste toerental en let op dat u het maximaal toegelaten toerental dat in de freeskop staat gegraveerd niet overschrijdt.
- De freeskop mag nooit worden tegengehouden door een zijdelingse druk. Houdt andere delen van uw freeskop schoon, zodat de spanen zonder problemen afgevoerd kunnen worden.
- Slijp of vervang de freesmessen op tijd om oververhitting van de motor en de messen te voorkomen en de levensduur van de messen te verlengen. Dat wil zeggen zodra de kwaliteit van het freeswerk niet meer voldoet en/of zodra de snijkant is afgerond tot 0,2 mm.
- Reinig de messen na gebruik en check bij langdurig gebruik de zijdkanten van de tanden om wrijving door ophoping te voorkomen. Gebruik hiervoor een harsoplosmiddel.
- Voor gebruik van het freesgereedschap, ook al is het nieuw, controleren of de bevestigingsschroeven goed zijn aangedraaid.
- Het is verboden enige verandering aan het gereedschap aan te brengen.
- Verander nooit de constructie van de frees of de geometrische snijhoek.
- Verander nooit de ruimte tussen de snijhoek en het lichaam of de ruimte tussen het lichaam en de contra-messen. De nodige ruimte is voorgeschreven door de Europese standaard specificaties EN 847-1.
- Onze freesgereedschappen zijn gemaakt volgens deze specificaties EN 847-1.
- De gereedschappen zijn uitsluitend bestemd voor het bewerken van hout en plaatmaterialen waaronder ook b.v. MDF.
- De freesmessen mogen uitsluitend door een erkende slijpdienst worden nageslepen.

*Het niet naleven van deze instructies kan leiden tot ernstige schade aan de freesgereedschappen en uw gezondheid.*



## Universeelkoppen

### Uni-freeskop 40x4 enkelvoudig

Zonder spaanbegrenzers!

**Toepassing:** Het bewerken van zacht- en hardhout met de diverse profielmessen in de maten 40x4.

**Uitvoering:** Slijtvaste aluminium kop, compleet met twee rechte messen M0.

Bestelnr.	D	B	Z	d	rpm	P
3400.20A	68	40	2	20	8000-9000	A
3401.30A	100	40	2	30	6000-9000	A

**Toebehoren:**

Bestelnr.	Omschrijving	is voor:
Messen 40X4	Zie pagina 45-54	A

**MEC**

**3400**



### Uni-freeskop 40x4 en 50x4

**Toepassing:** Het bewerken van zacht- en hardhout met de diverse profielmessen in de maten 40x4 en 50x4.

**Uitvoering:** Slijtvaste aluminium of stalen kop, compleet met set rechte messen en keermessen M0.

Bestelnr.	D	B	Z	L	d	rpm	P
3378.30S	78	40	2		30	8000-9000	A
3300.30A	100	40/50	2		30	5500-8400	A
3300.30S	100	40/50	2		30	5500-8400	A
3301.30A	120	40/50	2		30	4800-7400	A
3301.40A	120	40/50	2		40	4800-7400	A
3301.30S	120	40/50	2		30	4800-7400	A
3301.40S	120	40/50	2		40	4800-7400	A

**Toebehoren:**

Bestelnr.	Omschrijving	is voor:
Messen 40X4	Zie pagina 45-54	A
Messen 50x4	Zie pagina 55-59	A

**MAN**

**3300**

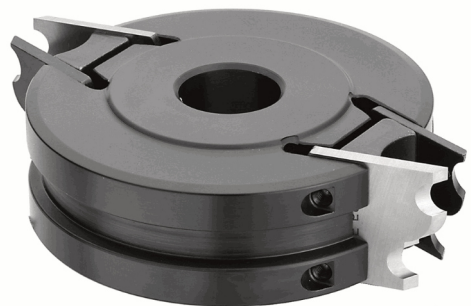

### Uni-freeskop 40/50x4 met flens

**Toepassing:** Het bewerken van zacht- en hardhout met de diverse profielmessen in de maten 40x4 en 50x4.

**Uitvoering:** Slijtvaste stalen kop, compleet met set rechte messen en keermessen M0.

Bestelnr.	D	B	Z	d	rpm	P
3310.30S	114	40/50	2	30	5000-5800	A
3310.40S	114	40/50	2	40	5000-5800	A

**Toebehoren:**

Bestelnr.	Omschrijving	is voor:
Messen 40X4	Zie pagina 45-54	A
Messen 50x4	Zie pagina 55-59	A

**MAN**

**3310**

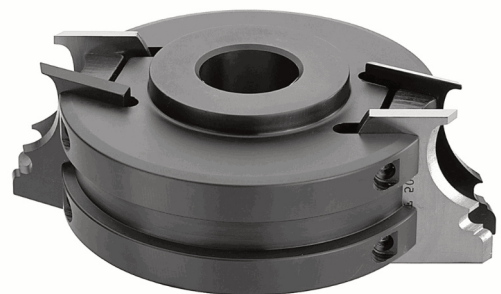

# Freeskoppen

3320

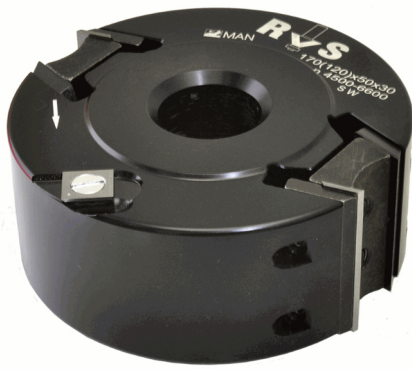

## MAN Uni-freeskop 40/50x4 en 50x5,5

Ook te gebruiken als sponningkop

**Toepassing:** Het bewerken van zacht- en hardhout met diverse profielmessen in de maten 40x4, 50x4 en 50x5,5.

**Uitvoering:** Slijtvaste aluminium kop, compleet met 2 voorsnijders, 2 HM wisselmessen en 2 stalen keermessen.

Bestelnr.	D	B	Z	V	d	rpm	P
3320.30A	96	50	2	2	30	5100-7100	A
3321.30A	120	50	2	2	30	4500-6600	A
3322.40A	120	50	2	2	40	4500-6600	A

### Toebehoren:

Bestelnr.	Omschrijving	is voor:
Messen 40x4	Zie pagina 45-54	A
Messen 50x4	Zie pagina 55-59	A
Messen 50x5,5	Zie pagina 60-62	A
L50	50x12x1,5/2-sn	A
LV142	14x14x2/4sn	A

3330

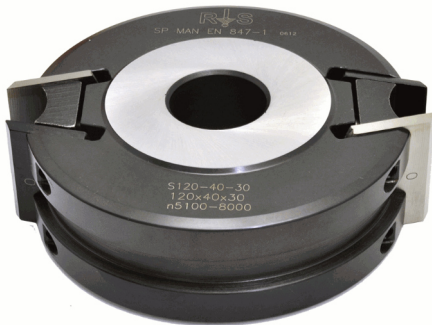

## MAN Uni-freeskop economy 40x4

**Toepassing:** Het bewerken van zacht- en hardhout met diverse profielmessen in de maat 40x4

**Uitvoering:** Slijtvaste stalen kop, compleet met set rechte messen/keermessen M0.

Bestelnr.	D	B	Z	d	rpm	P
3330.30S	120	40	2	30	5100-8000	A
3330.40S	120	40	2	40	5100-8000	A

### Toebehoren:

Bestelnr.	Omschrijving	is voor:
Messen 40x4	Zie pagina 45-54	A

3340

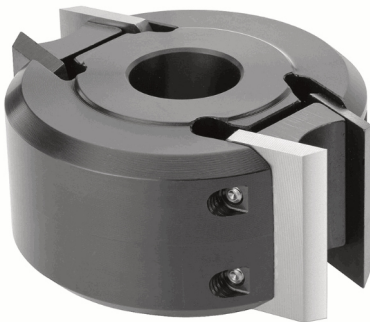

## MAN Uni-freeskop 50x5.5

**Toepassing:** Het bewerken van zacht- en hardhout met diverse profielmessen in de maat 50x5,5

**Uitvoering:** Slijtvaste aluminium of stalen kop, compleet met set rechte messen en stalen keermessen.

Bestelnr.	D	B	Z	d	rpm	P
3340.30A	120	50	2	30	4000-6000	A
3340.40A	120	50	2	40	4000-6000	A
3340.30S	110	50	2	30	4500-6500	A
3340.40S	120	50	2	40	4500-6500	A

### Toebehoren:

Bestelnr.	Omschrijving	is voor:
Messen 50x5,5	Zie pagina 60-62	A

3350

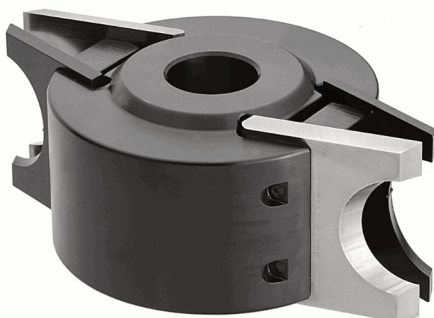

## MAN Uni-freeskop 60x5.5

**Toepassing:** Het bewerken van zacht- en hardhout met diverse profielmessen in de maat 59/64. Kwaliteit messen is HSS-E Zie pag 65-66.

**Uitvoering:** Slijtvaste stalen kop zonder messenset.

Bestelnr.	D	B	Z	d	rpm	P
3345.30A	120	60	2	30	4500-6500	A

### Toebehoren:

Bestelnr.	Omschrijving	is voor:
Messen 60x5,5	Zie pagina 63	A

## Uni-freeskop 59/64

**Toepassing:** Het bewerken van zacht- en hardhout met diverse profielmesses in de maat 59/64. Kwaliteit messen is HSS-E Zie pag 65-66.

**Uitvoering:** Slijtvaste stalen kop zonder messenset.

Bestelnr.	D	B	Z	d	rpm	P
3350.30S	110	65	2	30	4700-5000	
3350.40S	110	65	2	40	4700-5000	

**Toebehoren:**

Bestelnr.	Omschrijving	is voor:
Messen 59/64	Zie pagina 67	

MAN

3350

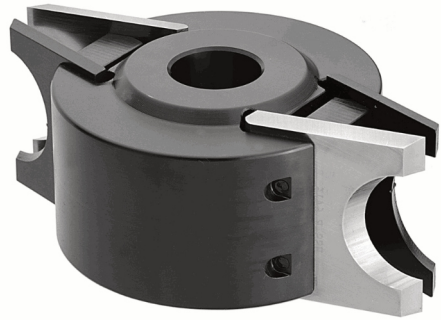

## Uni-freeskop 90 hoog

**Toepassing:** Het bewerken van zacht- en hardhout met diverse profielmesses in de maat 90 hoog

**Uitvoering:** Slijtvaste stalen kop zonder messenset.

Bestelnr.	D	B	Z	d	rpm	P
3360.40S	120	90	2	40	5300-6500	A

**Toebehoren:**

Bestelnr.	Omschrijving	is voor:
Messen 90x5,5	Zie pagina 67	A

MAN

3360



## In hoogte verstelbare universeelkop

\* is op aanvraag

**Toepassing:** Voor afkanten en afronden van zacht- en hardhout en plaatmateriaal op een stationaire freesmachine. Snijhoogte kan worden aangepast van 40-80mm met behulp van meegeleverde pasringen.

**Uitvoering:** Slijtvaste stalen kop compleet met rechte messen en keermessen M0. Ook als sponningkop te gebruiken.

Bestelnr.	D	B	Z	d	rpm	P
5500.30S	135	40-80	4	30	4500-7000	A
* 5500.40S	135	40-80	4	40	4500-7000	A

**Toebehoren:**

Bestelnr.	Omschrijving	is voor:
Messen 40X4	Zie pagina 45-54	A

MAN

5500



# Freeskoppen

5400

## MEC In hoogte verstelbare universeelkop

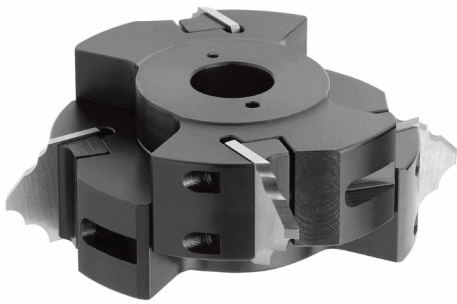

**Toepassing:** Voor afkanten en afronden van zacht- en hardhout en plaatmateriaal op een stationaire freesmachine. Snijhoogte kan worden aangepast van 40-80mm met behulp van meegeleverde pasringen.

**Uitvoering:** Slijtvaste stalen kop compleet met rechte messen M0. Ook als sponningkop te gebruiken.

Bestelnr.	D	B	Z	d	rpm	P
5400.30S	135	40-80	4	30	4500-7000	A



### Toebehoren:

Bestelnr.	Omschrijving	is voor:
Messen 40X4	Zie pagina 45-54	A

4500

## MEC Uni-freeskop rugvertande messen



**Toepassing:** Voor het bewerken van zacht- en hardhout met rugvertande (RVT messen) messen

**Uitvoering:** Slijtvaste stalen kop.

Bestelnr.	D	B	Z	d	rpm	P
4500.30S	122	130	2	30	6000	A

### Toebehoren:

Bestelnr.	Omschrijving	is voor:
RVT messen	op aanvraag	A

## Groeffrezen

### Groeffrezen WM variabel met klok

\* is op aanvraag

**Toepassing:** Voor nauwkeurigegroeven en sleuven in zacht hout, hardhout en plaatmateriaal (ev. met coating).

**Uitvoering:** Slijtvastestalen kop, compleet met HM wisselmessen. De voorsnijders zorgen voor een betere afwerking. Snijbreedte aan te passen met de mechanische instelling zonder de kop van de machine te halen.

Bestelnr.	D	B	Z	V	T	d	rpm	P
* 3100.30S	160	4-7,5	4	4	30	30	4800-8300	A
3101.30S	180	4-7,5	8	4	35	30	4300-7500	A
* 3101.40S	180	4-7,5	8	4	35	40	4300-7500	A
* 3103.30S	160	8-15	4	4	30	30	4800-8300	B
3104.30S	180	8-15	4	4	35	30	4300-7500	B
3104.40S	180	8-15	4	4	35	40	4300-7500	B
3106.30S	200	8-15	4	4	45	30	3800-6600	B
3106.40S	200	8-15	4	4	45	40	3800-6600	B
* 3107.30S	160	12,5-24	4	4	30	30	4800-8300	C
3108.30S	180	12,5-24	4	4	35	30	4300-7500	C
3108.40S	180	12,5-24	4	4	35	40	4300-7500	C
3109.30S	200	12,5-24	4	4	45	30	3800-6600	C
3109.40S	200	12,5-24	4	4	45	40	3800-6600	C

#### Toebehoren:

Bestelnr.	Omschrijving	is voor:
LV182	18x18x1,95/4sn	A
LV141	14x14x1,2/4sn	A
L76	7,5x12x1,5/2sn	B
LV142	14x14x2/4sn	BC
LV12	12x12x1,5/4sn	C

MAN

3100

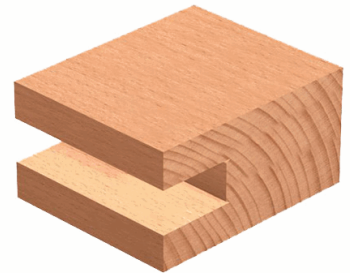

### Groeffrezen WM variabel

**Toepassing:** Voor nauwkeurigegroeven en sleuven in zacht hout, hardhout en plaatmateriaal (ev. met coating).

**Uitvoering:** Slijtvastestalen kop, compleet met HM wisselmessen. De voorsnijders zorgen voor een betere afwerking. Snijbreedte kan worden aangepast met behulp van de meegeleverde ringen.

Bestelnr.	D	B	Z	V	T	d	rpm	P
3131.30S	150	8-30	6	4	45	30	5000-8000	B
3132.40S	160	8-30	6	4	37	40	4800-8300	B

#### Toebehoren:

Bestelnr.	Omschrijving	is voor:
L76	7,5x12x1,5/2sn	B
LV142	14x14x2/4sn	B
L15	15x12x1,5/2sn	B

MAN

3130



# Freeskoppen

3120

## MAN Groeffrezen WM variabel

Uit te breiden tot 3-delige set met grotere snijbreedte door plaatsing van tussenring 3150 (zie pag.14)

**Toepassing:** Voor nauwkeurigegroeven en sleuven in zacht hout, hardhout en plaatmateriaal (ev. met coating).

**Uitvoering:** Slijtvaste stalen kop, compleet met HM wisselmessen. De voorsnijders zorgen voor een betere afwerking. Snijbreedte kan worden aangepast met behulp van de meegeleverde ringen.

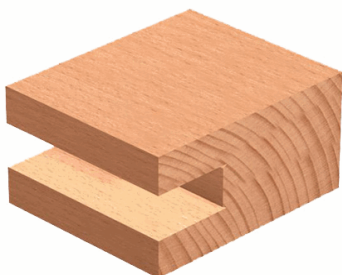

Bestelnr.	D	B	Z	V	T	d	rpm	P
3120.30S	160	4-7,5	4	4	38	30	4800-8300	A
3120.40S	160	4-7,5	4	4	38	40	4800-8300	A
3121.30S	180	4-7,5	8	4	38	30	4200-7400	A
3121.40S	180	4-7,5	8	4	38	40	4200-7400	A
3122.30S	160	8-15	4	4	37	30	4800-8300	B
3122.40S	160	8-15	4	4	37	40	4800-8300	B
3123.30S	180	8-15	4	4	47	30	4300-7500	B
3123.40S	180	8-15	4	4	47	40	4300-7500	B
3124.30S	200	8-15	4	4	45	30	3800-6500	B

### Toebehoren:

Bestelnr.	Omschrijving	is voor:
LV182	18x18x1,95/4sn	A
LV141	14x14x1,2/4sn	A
L76	7,5x12x1,5/2sn	B
LV142	14x14x2/4sn	B

3150

## MAN Tussenringen

Koppelen aan de hand van P, Q, of R

**Toepassing:** uitbreiding op de koppen uit de 3120 serie

**Uitvoering:** op twee diameters en drie snijbreedtes.



Bestelnr.	D	B	Z	T	d	rpm	P
3150.30S	160	7,5	2	38	30	4800-8300	P
3151.30S	180	7,5	2	47	30	4200-7400	P
3152.30S	160	15	2	38	30	4800-8200	Q
3153.30S	180	15	2	47	30	4400-7400	Q
3154.30S	160	20	2	38	30	4800-8200	R
3155.30S	180	20	2	47	30	4400-7400	R

### Toebehoren:

Bestelnr.	Omschrijving	is voor:
L76	7,5x12x1,5/2sn	P
L15	15x12x1,5/2sn	Q
L20	Mes 20x12x1,5/2sn	R

## Groeffrezen WM variabel

ook als Sponningkop te gebruiken

**Toepassing:** Voor het maken van nauwkeurigegroeven en sleuven in zacht hout, hardhout en plaatmateriaal (ev. met coating) op een stationaire freesmachine.

**Uitvoering:** Slijtvastestalen kop, compleet met HM wisselmessen (zowel de messen als de voorsnijders) De voorsnijders zorgen voor een betere afwerking. Snijbreedte kan worden aangepast met behulp van de meegeleverde ringen.

Bestelnr.	D	B	Z	V	T	d	rpm	P
5100.30S	160	20,6-40	4	4	42	30	4800-8000	A
5101.30S	160	30,6-60	4	4	42	30	4800-8000	B
5102.30S	160	50,6-100	4	4	42	30	4800-8000	C

### Toebehoren:

Bestelnr.	Omschrijving	is voor:
L20	Mes 20x12x1,5/2sn	A
L30	Mes 30x12x1,5/2sn	B
L50	50x12x1,5/2-sn	C
LV142	14x14x2/4sn	ABC

MAN

5100

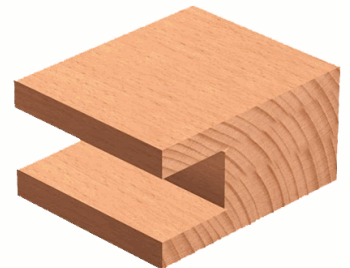
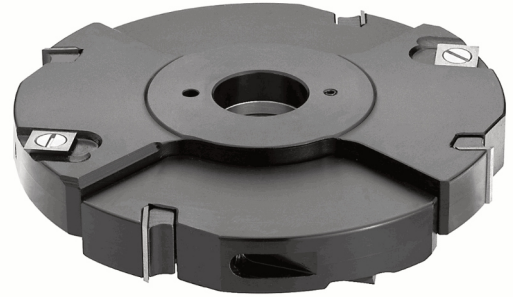

## Groeffrezen WM variabel "economy"

**Toepassing:** Voor het maken van groeven en sleuven in zacht hout, hardhout en plaatmateriaal (ev. met coating) op een stationaire freesmachine.

**Uitvoering:** Uitvoering "Economy". Aluminium kop. Snijbreedte kan worden aangepast met behulp van de meegeleverde ringen.

Bestelnr.	D	B	Z	T	d	rpm	P
3140.30A	160	14-28	4	64	30	5000-8000	A
3140.40A	160	14-28	4	59	40	5000-8000	A
3141.30A	160	20-39	4	64	30	5000-8000	B
3141.40A	160	20-39	4	59	40	5000-8000	B

### Toebehoren:

Bestelnr.	Omschrijving	is voor:
LV142	14x14x2/4sn	A
L20	Mes 20x12x1,5/2sn	B

MAN

3140

in

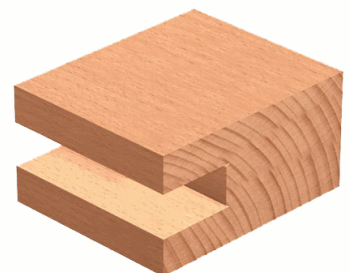
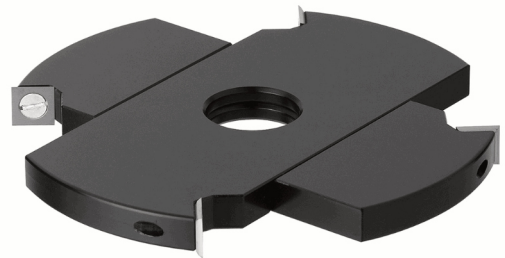

# Freeskoppen

3 1 7 0

## MAN Groeffrezen WM XXL

\* is op aanvraag

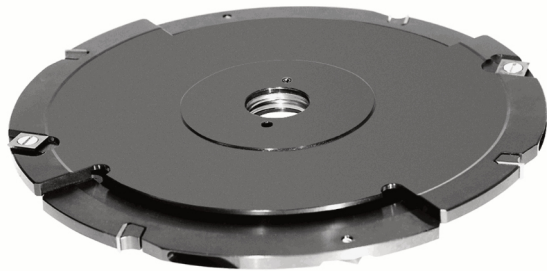

**Toepassing:** Voor het maken van nauwkeurigegroeven en sleuven in zacht hout, hardhout en plaatmateriaal (ev. met coating) op een stationaire freesmachine.

**Uitvoering:** Slijtvaste stalen kop, compleet met HM wisselmessen (zowel de messen als de voorsnijders) De voorsnijders zorgen voor een betere afwerking. Snijbreedte kan worden aangepast met behulp van de meegeleverde ringen.

Bestelnr.	D	B	Z	V	T	d	rpm	P
* 3170.30A	200	8,5-15	4	4	75	30	4000-5000	A
* 3171.30A	250	8,5-15	4	4	100	40	3000-4500	A

### Toebehoren:

Bestelnr.	Omschrijving	is voor:
L76	7,5x12x1,5/2sn	A
LV142	14x14x2/4sn	A

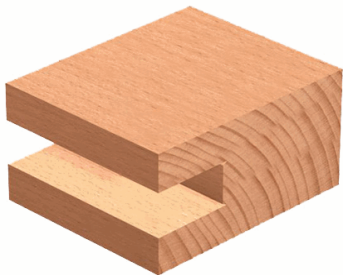

3 1 8 0

## MAN Groeffrezen HM variabel

met HM vaste messen



**Toepassing:** Voor het maken van nauwkeurigegroeven en sleuven in zacht hout, hardhout en plaatmateriaal (ev. met coating) op een stationaire freesmachine.

**Uitvoering:** twee-delige stalen freeskop. Snijbreedte kan worden aangepast met behulp van de meegeleverde ringen.

Bestelnr.	D	B	Z	d	rpm	P
3180.30S	120	5-10	4	30	6000-10000	
3182.40S	200	8-15	4	40	6500	

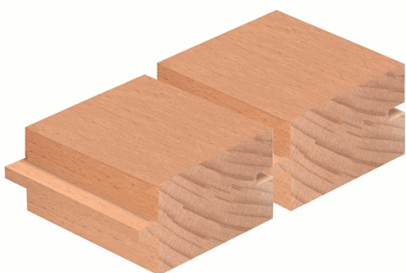



## Groeffrezen

met HM vaste messen

**Toepassing:** Voor het vervaardigen van groeven en sleuven in zacht- en hardhout en plaatmateriaal (ev. met coating) Kan gebruikt worden met pasringen voor het maken van lipverbindingen.

**Uitvoering:** Slijtvastestalen kop (Z=2).

Bestelnr.	D	B	Z	d	rpm	P
3681.30S	120	6	2	30	10500	
3682.30S	120	8	2	30	10500	
3684.30S	120	12	2	30	10500	

MAN

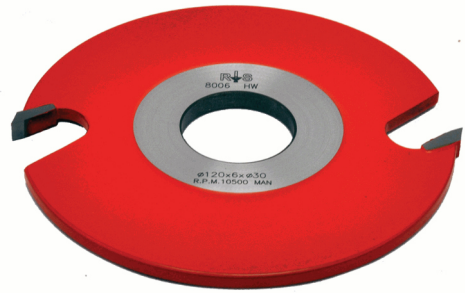

## Groeffrezen WM

**Toepassing:** Voor het maken van nauwkeurigegroeven en sleuven in zachthout, hardhout en plaatmateriaal (ev. met coating) op een stationaire freesmachine.

**Uitvoering:** Slijtvastestalen kop, compleet met HM wisselmessen (zowel de messen als de voorsnijders) De voorsnijders, LV141 zorgen voor een betere afwerking.

Bestelnr.	D	B	Z	V	T	d	rpm	P
3600.30S	125	4	4	4	37	30	6100-10600	A
3601.30S	125	5	4	4	37	30	6100-10600	B
3602.30S	125	6	4	4	37	30	6100-10600	C
3603.30S	125	8	4	4	37	30	6100-10600	D
3604.30S	125	10	4	4	37	30	6100-10600	E
3605.30S	125	12	4	4	37	30	6100-10600	F
3606.30S	150	4	4	4	49	30	5100-8900	A
3607.30S	150	5	4	4	49	30	5100-8900	B
3608.30S	150	6	4	4	49	30	5100-8900	C
3609.30S	150	8	4	4	49	30	5100-8900	D
3610.30S	150	10	4	4	49	30	5100-8900	E
3611.30S	150	12	4	4	49	30	5100-8900	F
3612.30S	180	4	4	4	64	30	4200-7400	A
3614.30S	180	6	4	4	64	30	4200-7400	C
3615.30S	180	8	4	4	64	30	4200-7400	D
3616.30S	180	10	4	4	64	30	4200-7400	E
3617.30S	180	12	4	4	64	30	4200-7400	F

MAN

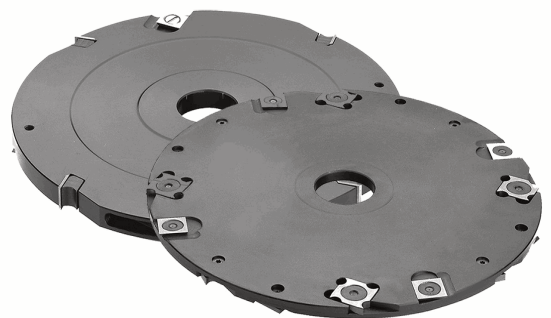

### Toebehoren:

Bestelnr.	Omschrijving	is voor:
LV182	18x18x1,95/4sn	A
LV1825	18x18x2,5/4sn	B
LV183	18x18x3/4sn	C
L76	7,5x12x1,5/2sn	D
L96	9,6x12x1,5/2sn	E
LV12	12x12x1,5/4sn	F
LV141	14x14x1,2/4sn	ABC
LV142	14x14x2/4sn	DEF

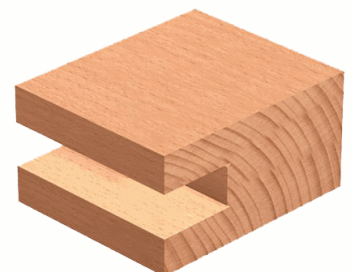

# Freeskoppen

## GR125



## MAN Groefzagen 125 mm - Industrial

ook voor de cirkelzaag!

**Toepassing:** Voor het maken van nauwkeurigegroeven en sleuven in zacht hout en hardhout.

**Uitvoering:** Slijtvaste stalen body. Met spaanbegrenzer.

Bestelnr.	D	B	T	d	rpm	P
GR1251530	125	1,5	12	30	12000	
GR1252030	125	2,0	12	30	12000	
GR1252530	125	2,5	12	30	12000	
GR1253030	125	3,0	12	30	12000	
GR1254030	125	4,0	12	30	12000	
GR1255030	125	5,0	12	30	12000	
GR1256030	125	6,0	12	30	12000	
GR1257030	125	7,0	12	30	12000	
GR1258030	125	8,0	12	30	12000	

## GR150 en GR180



## MEC Groefzagen 150/180 mm - Industrial

ook voor de cirkelzaag!

**Toepassing:** Voor het maken van nauwkeurigegroeven en sleuven in zacht hout en hardhout.

**Uitvoering:** Slijtvaste stalen body.

Bestelnr.	D	B	T	d	rpm	P
GR1502030	150	2,0	12	30	12000	
GR1503030	150	3,0	12	30	12000	
GR1504030	150	4,0	12	30	12000	
GR1505030	150	5,0	12	30	12000	
GR1506030	150	6,0	12	30	12000	
GR1507030	150	7,0	12	30	12000	
GR1508030	150	8,0	12	30	12000	
GR1509030	150	9,0	12	30	12000	
GR1501030	150	10	12	30	12000	
GR1804030	180	4,0	12	30	10000	
GR1804040	180	4,0	12	40	10000	
GR1805030	180	5,0	12	30	10000	
GR1805040	180	5,0	12	40	10000	
GR1806030	180	6,0	12	30	10000	
GR1806040	180	6,0	12	40	10000	
GR1807030	180	7,0	12	30	10000	
GR1807040	180	7,0	12	40	10000	
GR1808030	180	8,0	12	30	10000	
GR1808040	180	8,0	12	40	10000	
GR1809030	180	9,0	12	30	10000	
GR1809040	180	9,0	12	40	10000	
GR1801030	180	10	12	30	10000	
GR1801040	180	10	12	40	10000	

## Lamellofreesen

### Lamello groeffrees

met HM wisselmessen

**Toepassing:** Voor het frezen van groeven en sleuven in zacht- en hardhout en plaatmateriaal (ev. met coating).

**Uitvoering:** Slijtvastestalen kop, compleet met HM wisselmessen (zowel de messen als de voorsnijders). De voorsnijders zorgen voor een betere afwerking.

Bestelnr.	D	B	Z	V	d	rpm	P
3510.22S	100	3,97	2	2	22	7600-13400	A

#### Toebehoren:

Bestelnr.	Omschrijving	is voor:
LV141	14x14x1,2/4sn	A
LV182	18x18x1,95/4sn	A

MAN

3510



### Lamello groeffrees

Standaard; met HM vaste messen

**Toepassing:** Voor het frezen van groeven en sleuven in zacht- en hardhout en plaatmateriaal (ev. met coating).

**Uitvoering:** Slijtvastestalen kop met 6 vaste messen.

Bestelnr.	D	B	Z	d	rpm	P
3560.22S	100	3,97	6	22	7600-13400	

MAN

3560



### Lamellofreesen speciaal

3570: 1 x naaf en 3571: 2 x naaf

**Toepassing:** Voor het frezen van groeven en sleuven in zacht- en hardhout en plaatmateriaal (ev. met coating).

**Uitvoering:** Slijtvastestalen kop met 6 vaste messen.

Bestelnr.	D	B	Z	d	rpm	P
3570.22S	100	3,97	6	22	7600-13400	
3571.22S	100	3,97	6	22	7600-13400	

MAN

3570



3570 1x naaf

3571 2x naaf

### Lamello reparatiefrees

met HM vaste messen

**Toepassing:** Voor reparaties van lelijke plekken in hout (noesten of harsplekken).

**Uitvoering:** Slijtvastestalen kop met 4 vaste messen. 3580 heeft breedte 8mm en 3581 heeft breedte 15mm.

Bestelnr.	D	B	Z	d	rpm	P
3580.22S	100	8	4	22	7600-13400	
3581.22S	100	15	4	22	7600-13400	

MAN

3580



# Freeskoppen

## Schaafbankkoppen

7310

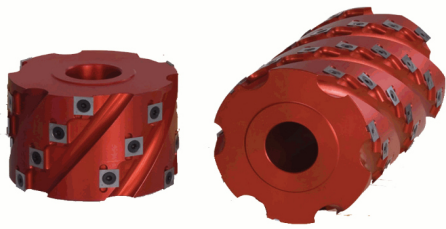

### MAN Schaafkoppen

met HM wisselmessen \* is op aanvraag

**Toepassing:** Voor het verwijderen van grote volumes van alle soorten hout met een hoge voedingsnelheid met kleine spaangrootte. Laag geluidsniveau

**Uitvoering:** Slijtvaste aluminium kop met HM wisselmessen. Andere profiellengtes op aanvraag.

Bestelnr.	D	B	Z	d	rpm	P
* 7310.40A	125	130	30	40	max 9000	A

#### Toebehoren:

Bestelnr.	Omschrijving	is voor:
LV142	14x14x2/4sn	A

7320

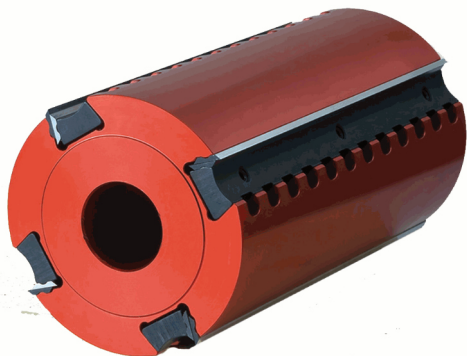

### MAN Schaafkoppen

met HM wisselmessen

**Toepassing:** Kop voor fijnafwerking. Grote spaanafvoerbaan voor hoge voedingsnelheden.

**Uitvoering:** Slijtvaste aluminium kop met HSS of HM wisselmessen in snelwisseluitvoering. De spanwig is aangevuld met een extra HSS mes tbv langere levensduur van de spaninrichting. Andere profiellengtes op aanvraag.

Bestelnr.	D	B	Z	T	d	rpm	P
7320.40A	125	130	4		40	max 9000	A

7340

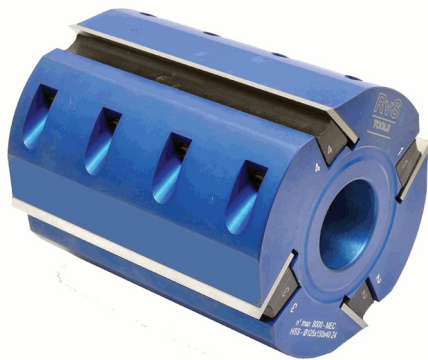

### MAN Schaafkoppen

**Toepassing:** Kop voor fijnafwerking.

**Uitvoering:** Slijtvaste aluminium kop met standaard schaaftmessen in HSS en eventueel HM schaaftmessen. Andere profiellengtes op aanvraag.

Bestelnr.	D	B	Z	d	rpm	P	
7340.40A	125	150	4		40	max 9000	A

## Sponningkoppen

### Sponningkoppen

met HM wisselmessen

**Toepassing:** Voor het maken van sponningen in zacht- en hardhout en plaatmateriaal (ev. met coating).

**Uitvoering:** Slijtvaste aluminium of stalen kop, compleet met HM messen en HM voorsnijders.

Bestelnr.	D	B	Z	V	d	rpm	P
3200.30A	100	30	2	4	30	7600-12000	A
3200.40A	100	30	2	4	40	7600-12000	A
3201.30A	100	50	2	4	30	7600-12000	C
3201.40A	100	50	2	4	40	7600-12000	C
3202.30A	125	30	2	4	30	6100-10300	A
3202.40A	125	30	2	4	40	6100-10300	A
3203.30A	125	40	2	4	30	6100-10300	B
3203.40A	125	40	2	4	40	6100-10300	B
3204.30A	125	50	2	4	30	6100-10300	C
3204.40A	125	50	2 <td 4	40	6100-10300	C	
3205.30S	125	60	2	4	30	6100-10300	D
3205.40S	125	60	2	4	40	6100-10300	D

#### Toebehoren:

Bestelnr.	Omschrijving	is voor:
L30	Mes 30x12x1,5/2sn	A
L40	40x12x1,5/2sn	B
L50	50x12x1,5/2-sn	C
L60	60x12x1,5/2sn	D
LV142	14x14x2/4sn	ABCD

MAN

3200

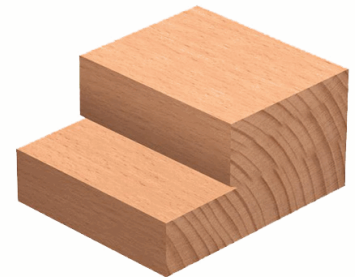
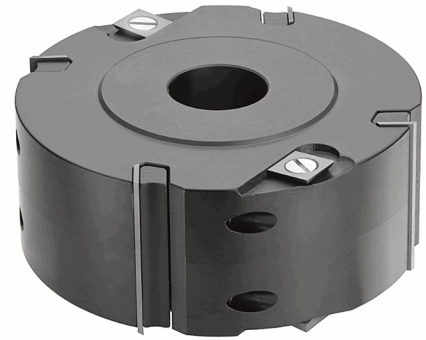

## Stapelbare schaafkoppen

met HM wisselmessen \* is op aanvraag

**Toepassing:** Voor het schaven van zacht- en hardhout en plaatmateriaal (ev. met coating).

**Uitvoering:** Slijtvaste aluminium kop, compleet met HM messen en HM voorsnijders. Stapelbaar met 2,5mm overlap per set. Dus bij 2 koppen is B gelijk aan 50+50-2,5 = 97,5mm.

Bestelnr.	D	B	Z	d	rpm	P
* 3700.30A	125	30	2	30	6100-10300	A
* 3701.30S	125	50	2	30	6100-10300	B

#### Toebehoren:

Bestelnr.	Omschrijving	is voor:
L30	Mes 30x12x1,5/2sn	A
L50	50x12x1,5/2-sn	B

MAN

3700

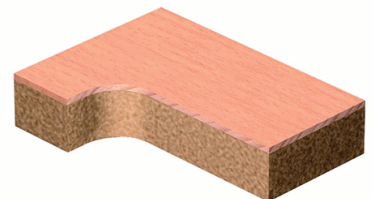

# Freeskoppen

## Verlijmkoppen

4300

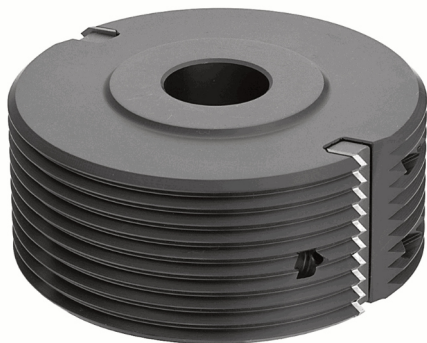

### MAN Verlijmkop 90 °

met HM wisselmessen

**Toepassing:** Voor het maken van V-vormige lijmverbindingen in zacht- en hardhout en plaatmateriaal.

**Uitvoering:** Slijtvaste aluminium kop, compleet met 2 HM wisselmessen.

Bestelnr.	D	B	Z	d	rpm	P
4300.30A	120	50	2	30	6400-10600	A



#### Toebehoren:

Bestelnr.	Omschrijving	is voor:
09.1301F	HM mes tbv 4300	A

4810



### MAN Verlijmkop 90 °

met HM wisselmessen

**Toepassing:** Voor het vervaardigen van enkel- of meervoudige lijmverbindingen in zacht- en hardhout en plaatmateriaal.

**Uitvoering:** Slijtvaste aluminium kop, compleet met 2 HM wisselmessen.

Bestelnr.	D	B	Z	T	d	rpm	P
4810.30A	130	60	2		30	6500-9500	A

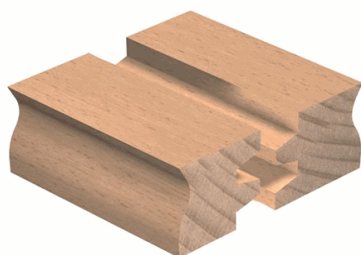

#### Toebehoren:

Bestelnr.	Omschrijving	is voor:
09.1860F	HM mes tbv 4810	A

# Freeskoppen

## Verlijmkop 45°

met HM wisselmessen

**Toepassing:** Voor het maken van 45 ° lijmverbindingen in zacht- en hardhout en plaatmateriaal met een dikte van 14-28mm. Kan ook worden gebruikt voor het verbinden van horizontale stukken hout.

**Uitvoering:** Slijtvastestalen kop, compleet met 2 HM messen. Omvang lijmprofiel is 9x9 mm.

Bestelnr.	D	B	Z	d	rpm	P
4800.30S	170	40	2	30	5500-10000	A

MAN

4800

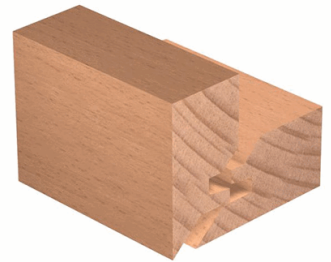

### Toebehoren:

Bestelnr.	Omschrijving	is voor:
10.0026F	HM mes tbv 4040/4800	A

## Zwenkverlijmkop

met HM wisselmessen \* is op aanvraag

**Toepassing:** Voor het lijmen onder verschillende hoeken tot ca +/- 45° in zacht- en hardhout en plaatmateriaal op een stationaire freesmachine.

**Uitvoering:** Freeskop in stalen uitvoering, compleet met 2 HM wisselmessen. Freeshoek kan worden aangepast in stappen van 7,5° door gebruik te maken van het afstelmechanisme.

Bestelnr.	D	B	Z	T	d	rpm	P
* 4040.30S	170	40	2	28	30	4500-6000	A

MAN

4040

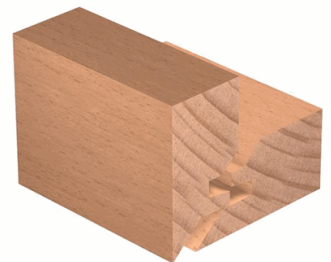

### Toebehoren:

Bestelnr.	Omschrijving	is voor:
10.0026F	HM mes tbv 4040/4800	A

# Freeskoppen

## Afschuinen en kanten

4010

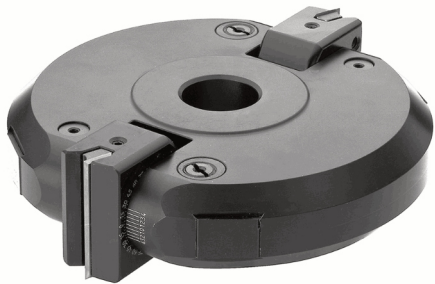

### MAN Zwenkmessenkop +/- 75°

met HM wisselmessen. Snijhoogte bij 45°: zie kolom T

**Toepassing:** Voor het afschuinen naar verschillende hoeken in zacht- en hardhout en plaatmateriaal.

**Uitvoering:** Freeskop in slijtvaste aluminium uitvoering, compleet met HM wisselmessen. Freeshoek kan worden aangepast van +/- 75° in stappen van 7,5° door gebruik te maken van het afstelmechanisme. Fijnaanpassing met 1° is mogelijk m.b.v een zg. nonius-schaal.

Bestelnr.	D	B	Z	T	d	rpm	P
4010.30A	120	40	2	27	30	6400-8500	A

#### Toebehoren:

Bestelnr.	Omschrijving	is voor:
L40	40x12x1,5/2sn	A



4020

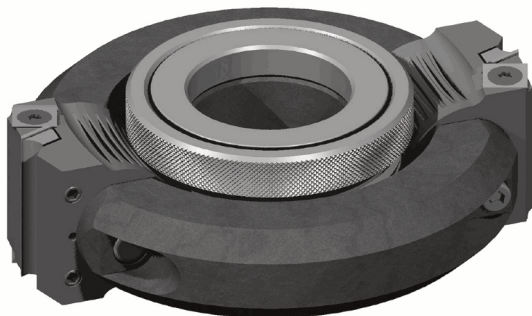

### MAN Zwenkmessenkop +/- 75° met klok

met HM wisselmessen. Snijhoogte bij 45°: zie kolom T \* is op aanvraag

**Toepassing:** Voor het afschuinen naar verschillende hoeken in zacht- en hardhout en plaatmateriaal.

**Uitvoering:** Freeskop in slijtvaste stalen uitvoering, compleet met HM wisselmessen. Freeshoek kan traploos worden aangepast van +/-75° door gebruik te maken van de afstelklok. Nauwkeurigheid <0,5°.

Bestelnr.	D	B	Z	T	d	rpm	P
* 4020.30S	164	50	2	34	30	4500-6900	A

#### Toebehoren:

Bestelnr.	Omschrijving	is voor:
L50	50x12x1,5/2-sn	A
LV142	14x14x2/4sn	A





## Zwenkmessenkoppen +/- 90°

met HM wisselmessen. Snijhoogte bij 45°: zie kolom T

**Toepassing:** Voor het afschuinen naar verschillende hoeken in zacht- en hardhout en plaatmateriaal.

**Uitvoering:** Freeskoppen in slijtvaste aluminium uitvoering, compleet met HM wisselmessen. Freeshoek kan traploos worden aangepast middels een tandwieloverbrenging. Fijnaanpassing met 1° is mogelijk m.b.v een zg. nonius-schaal.

Bestelnr.	D	B	Z	T	d	rpm	P
4000.30A	160	50	2	34	30	4800-6000	A
4000.40A	160	50	2	34	40	4800-6000	A
4001.30A	170	60	2	41	30	4500-6000	B
4001.40A	170	60	2	41	40	4500-6000	B

### Toebehoren:

Bestelnr.	Omschrijving	is voor:
L50	50x12x1,5/2-sn	A
L60	60x12x1,5/2sn	B

MAN

4000

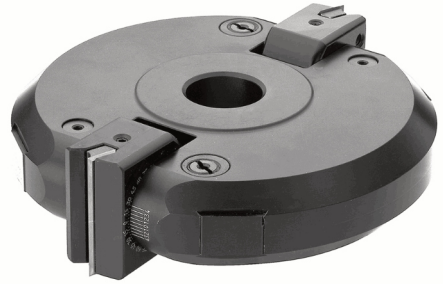

## Zwenkmessenkop "economy"

met HM wisselmessen. Snijhoogte bij 45°: zie kolom T

**Toepassing:** Voor het afschuinen naar verschillende hoeken in zacht- en hardhout en plaatmateriaal.

**Uitvoering:** Freeskop in aluminium uitvoering, compleet met HM wisselmessen. Freeshoek kan worden aangepast in stappen van 7,5° door gebruik te maken van het afstelmechanisme. Fijnaanpassing met 1° is mogelijk m.b.v een zg. nonius-schaal.

Bestelnr.	D	B	Z	T	d	rpm	P
4030.30A	120	40	2	27	30	6400-8500	A

### Toebehoren:

Bestelnr.	Omschrijving	is voor:
L40	40x12x1,5/2sn	A

MAN

4030



## 45° Freeskop

met HM vaste messen

**Toepassing:** Voor het afschuiven van zacht- en hardhout en plaatmateriaal op een stationaire freesmachine.

**Uitvoering:** Slijtvastestalen kop (Z=2).

Bestelnr.	D	B	Z	d	rpm	P
4080.30S	120	15	2	30	6500-11000	

MAN

4080

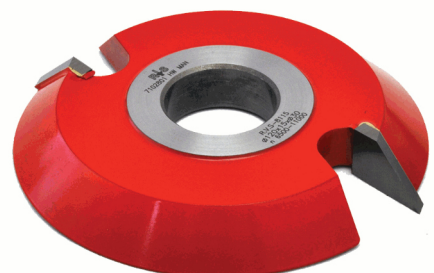

# Freeskoppen

4900

MAN

## Concaaf Convex (Hol/Bol) koppen

met HM wisselmessen. Concaaf is hol en Convex is bol \* is op aanvraag



**Toepassing:** Voor zacht- en hardhouten plaatmaterialen op een stationaire freesmachine. Alle freeskoppen kunnen worden gebruikt met een 100mm kopieerlager.

**Uitvoering:** Slijtvaste aluminium kop, compleet met HM wisselmessen. Tot R=30 concaaf- en convexdeel in 1 mes. Vanaf R=10 ook op aanvraag met D=40 mm leverbaar.

Bestelnr.	D	B	Z	R	d	rpm	P
4903.30A	106	20	2	3	30	7300-10100	A
4905.30A	110	20	2	5	30	7000-9900	B
4906.30A	112	20	2	6	30	6900-9700	C
4908.30A	116	20	2	8	30	6600-9500	D
4910.30A	120	25	2	10	30	6400-10000	E
4912.30A	124	30	2	12	30	6200-9800	F
4915.30A	130	35	2	15	30	5900-9500	G
4920.30A	140	40	2	20	30	5500-9000	H
4925.30A	150	60	2	25	30	5100-6000	I
4930.30A	153	60	2	30	30	4900-5800	J
* 4935.30A	172	80	2	35	30	4700-5700	K
4940.30A	180	100	2	40	30	4400-5600	L

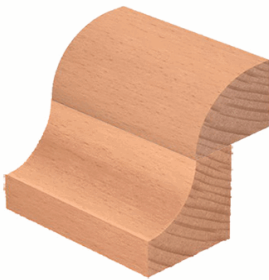

### Toebehoren:

Bestelnr.	Omschrijving	is voor:
09.19003F	HM mes R=3 hol/bol	A
09.19005F	HM mes R=5 hol/bol	B
09.19006F	HM mes R=6 hol/bol	C
09.19008F	HM mes R=8 hol/bol	D
09.19010F	HM mes R=10 hol/bol	E
09.19012F	HM mes R=12 hol/bol	F
09.19015F	HM mes R=15 hol/bol	G
09.19020F	HM mes R=20 hol/bol	H
09.19025F	HM mes R=25 hol/bol	I
09.19030F	HM mes R=30 hol/bol	J
09.19035F	HM mes R=35 bol	K
09.19036F	HM mes R=35 hol	K
09.19040F	HM mes R=40 bol	L
09.19041F	HM mes R=40 hol	L

# Freeskoppen

## Convex (bol) kop

met HM wisselmessen. R = 4,6,8 en 10 mm

**Toepassing:** Voor maken van kwartronde profielen aan zacht- en hardhout en plaatmateriaal op een stationaire freesmachine. Bij een verhoging of verlaging van de freeskop, selecteert de machine een andere radius.

**Uitvoering:** Slijtvaste aluminium kop, compleet met HM wisselmessen.

Bestelnr.	D	B	Z	d	rpm	P
4970.30A	180	50	2	30	4500-7500	A

### Toebehoren:

Bestelnr.	Omschrijving	is voor:
09.1950F	HM mes tbv 4970	A

MAN

4970

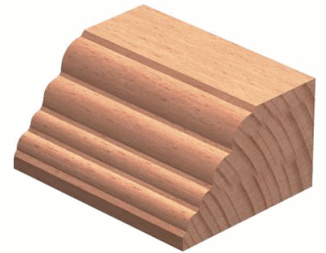

## Concaaf (hol) kop

met HM wisselmessen. R = 4,6,8 en 10 mm

**Toepassing:** Voor het maken van holprofielenaan zacht- en hardhout en plaatmateriaal op een stationaire freesmachine. Bij een verhoging of verlaging van de freeskop, selecteert de machine een andere radius.

**Uitvoering:** Slijtvaste aluminium kop, compleet met HM wisselmessen.

Bestelnr.	D	B	Z	d	rpm	P
4960.30A	180	60	2	30	4500-7500	A

### Toebehoren:

Bestelnr.	Omschrijving	is voor:
09.1960F	HM mes tbv 4960	A

MAN

4960

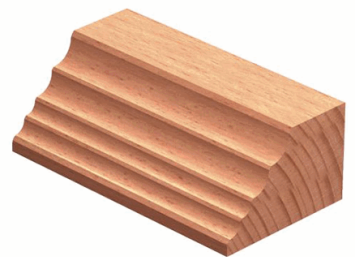

## Convex (bol) kop vaste messen

met HM vaste messen

**Toepassing:** kwartrond profiel aan zacht- en hardhout en plaatmateriaal op een stationaire freesmachine.

**Uitvoering:** Slijtvaste stalen kop met 2 vaste HM messen.

Bestelnr.	D	B	Z	R	d	rpm	P
4980.30S	100	10	2	5	30	7600-13400	
4981.30S	105	15	2	7	30	12000	
4982.30S	110	20	2	10	30	12000	
4983.30S	120	30	2	15	30	10500	

MAN

4980



# Freeskoppen

## Profielkoppen

5800

### MAN Freeskop voor Driepuntssluitingen

met HM wisselmessen

**Toepassing:** Voor het frezen van getrapte sleuven voor meerpuntssluitingen

**Uitvoering:** Slijtvaste stalen uitvoering, compleet met HM wisselmessen en 4 HM voorsnijders.



Bestelnr.	D	B	Z	V	d	rpm	P
5800.30S	180	20,3	2	2	30	4000-7500	A

#### Toebehoren:

Bestelnr.	Omschrijving	is voor:
09.2802F	HM mes tbv 5800	A
LV142	14x14x2/4sn	A

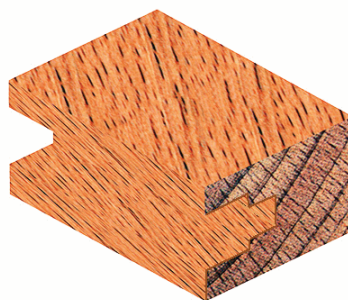
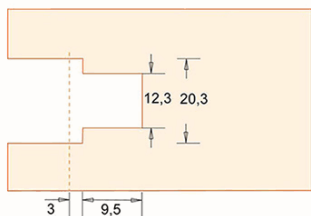

4410

### MAN Trapleuningfreeskop

met HM wisselmessen

**Toepassing:** Voor het vervaardigen van trapleuningen

**Uitvoering:** Stalen freeskop met twee HM messen.



Bestelnr.	D	B	Z	d	rpm	P
4410.30S	140	70	2	30	5500-9500	A

#### Toebehoren:

Bestelnr.	Omschrijving	is voor:
09.1470F	HM mes tbv 4410	A

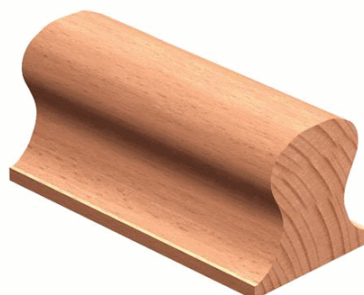
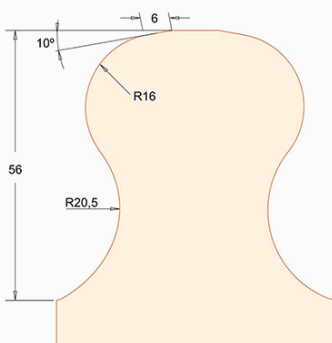

# Freeskoppen

## Profiel contra profiel freeskop

met HM wisselmessen

**Toepassing:** Voor het frezen van profielen en bijbehorende contraprofielen ter vervaardiging van diverse raamwerken. Het omstellen geschiedt eenvoudigweg door de hoogte van de freeskop te wijzigen.

**Uitvoering:** Aluminium freeskop waar 4 verschillende HM messen in passen. Z=2 .Compleet met set messen naar keuze.

Bestelnr.	D	B	Z	d	rpm	P
4200.30A	120	40	2	30	6400-8400	A
4200.40A	120	40	2	40	6400-8400	A

### Toebehoren:

Bestelnr.	Omschrijving	is voor:
09.1201F	HM mes 1 hol/bol	A
09.1202F	HM mes 2 hol/recht/bol	A
09.1203F	HM mes 3 s-vorm	A
09.1204F	HM mes 4 schuin	A

MAN

4200

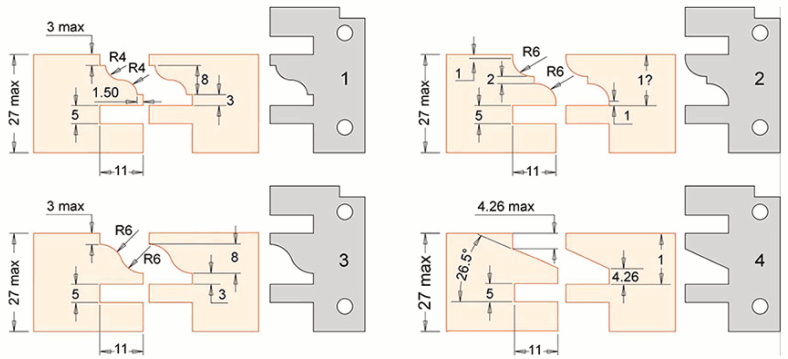
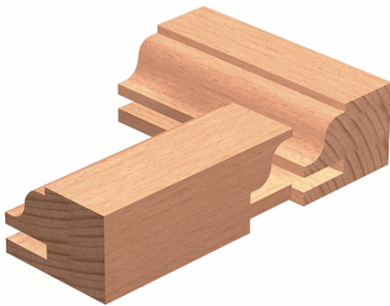

## Profiel contra profiel freeskop

met HM vaste messen

**Toepassing:** Voor het frezen van profielen en bijbehorende contraprofielen ter vervaardiging van diverse raamwerken. Het omstellen geschiedt door de volgorde van de freeskopdelen te wijzigen.

**Uitvoering:** Twee stalen freeskopdelen en bijbehorende ringen.

Bestelnr.	D	B	Z	d	rpm	P
4280.30S	116	22	2	30	max 10000	

MAN

4280

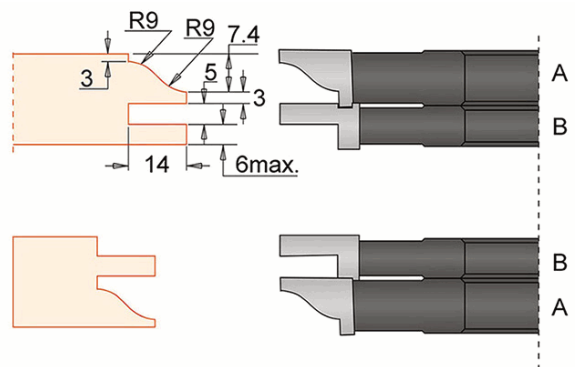
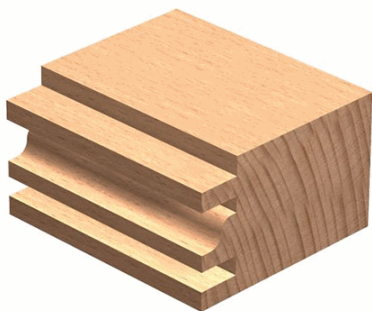

# Freeskoppen

4210

## MAN Profiel contra profiel freeskop

met HM wisselmessen \* is op aanvraag

**Toepassing:** Voor het frezen van profielen en bijbehorende contraprofielen ter vervaardiging van diverse raamwerken. Het omstellen geschiedt door de volgorde van de freeskopdelen te wijzigen.

**Uitvoering:** Aluminium freeskoppenset. Bevat 1 kop type A, 1 kop type B, 1 kop type C en twee ringen type D. Compleet met set messen naar keuze.

Bestelnr.	D	d	rpm	P
* 4210.30A	142	30	4400-7400	A
* 4210.40A	142	40	4400-7400	A

### Toebehoren:

Bestelnr.	Omschrijving	is voor:
09.27.301F	HM mes tbv 4210.A	A
09.27.302F	HM mes tbv 4210.A	A
09.27.303F	HM mes tbv 4210.A	A
09.27.304F	HM mes tbv 4210.A	A
09.27.305F	HM mes tbv 4210.A	A
09.27.311F	HM mes tbv 4210.B	A
09.27.312F	HM mes tbv 4210.B	A
09.27.313F	HM mes tbv 4210.B	A
09.27.314F	HM mes tbv 4210.B	A
09.27.315F	HM mes tbv 4210.B	A
L76	7,5x12x1,5/2sn	A
LV142	14x14x2/4sn	A

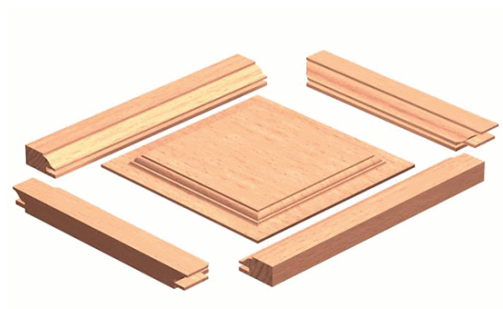



# Freeskoppen

4400

## MAN Profielkop

met HM wisselmessen

**Toepassing:** Voor het maken van een veelvoud aan profielen voor lijsten en het afwerken van randen

**Uitvoering:** Slijtvaste aluminium kop, compleet met twee HM messen. Zeer veel profielen mogelijk.

Bestelnr.	D	B	Z	d	rpm	P
4400.30A	120	40	2	30	6400-10000	A
4401.30A	160	50	2	30	4800-8300	A

### Toebehoren:

Bestelnr.	Omschrijving	is voor:
09.1401F	HM mes tbv 4400	A
09.1402F	HM mes tbv 4401	A

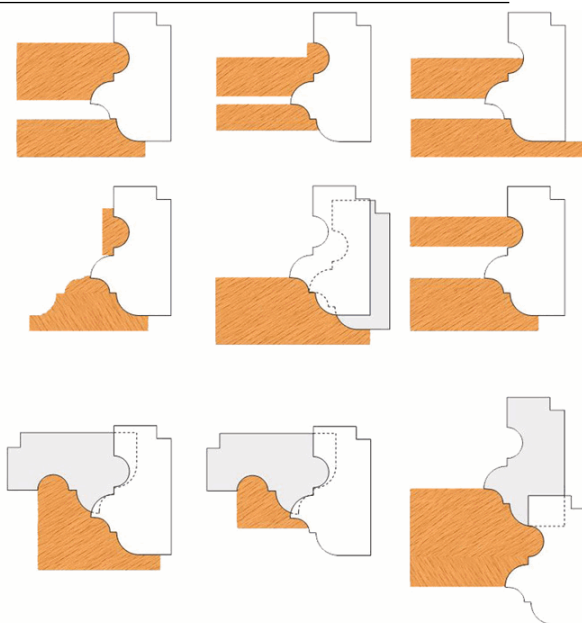
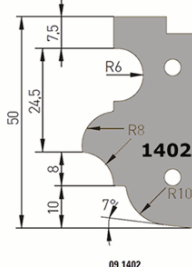
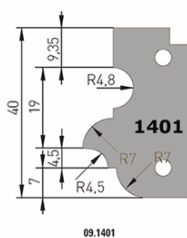

4480

## MAN Profielkop vaste messen

met HM vaste messen \* is op aanvraag

**Toepassing:** Voor het maken van een veelvoud aan profielen voor lijsten en het afwerken van randen

**Uitvoering:** Slijtvaste stalen kop, compleet met twee HM vaste messen. Zeer veel profielen mogelijk.

Bestelnr.	D	B	Z	d	rpm	P
* 4480.30S	120	40	2	30	10000	





## Bossingkoppen

### Bossingkop I

met HM wisselmessen

**Toepassing:** Geschikt voor het maken van 3 verschillend bossingprofielen in zacht- en hardhout en plaatmateriaal op een stationaire freesmachine.

**Uitvoering:** Slijtvaste aluminium kop, compleet met HM wisselmessen. De kop wordt standaard met 1 set messen naar keuze geleverd. Profiellengte ca. 48mm.

Bestelnr.	D	B	Z	d	rpm	P
4100.30A	160	20	2	30	4800-8000	A
4100.40A	160	20	2	40	4800-8000	A

#### Toebehoren:

Bestelnr.	Omschrijving	is voor:
09.1101F	HM mes tbv 4100	A
09.1102F	HM mes tbv 4100	A
09.1103F	HM mes tbv 4100	A

MAN

4100

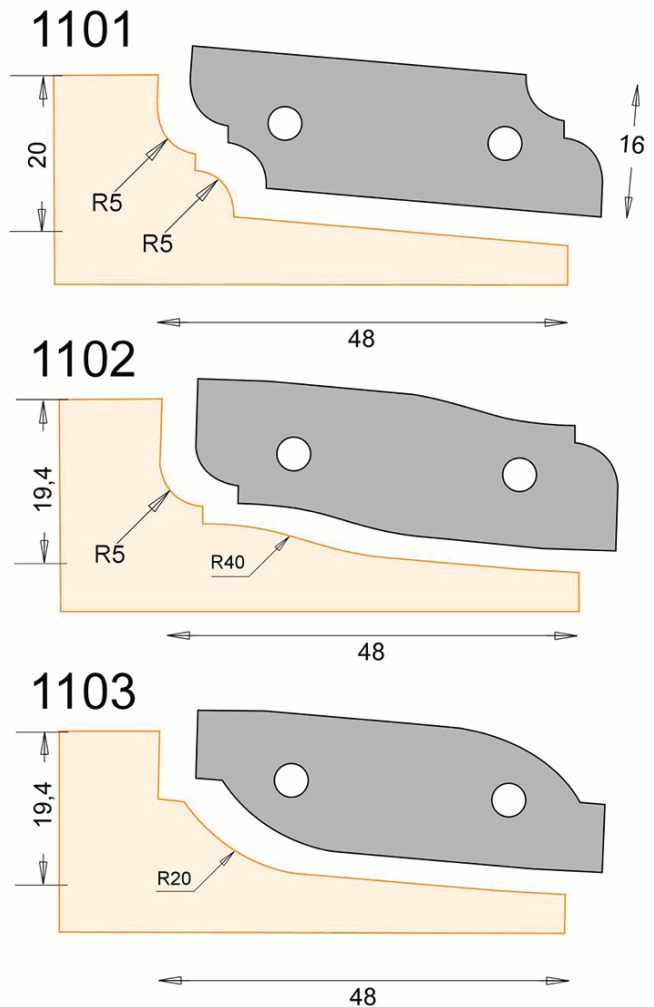
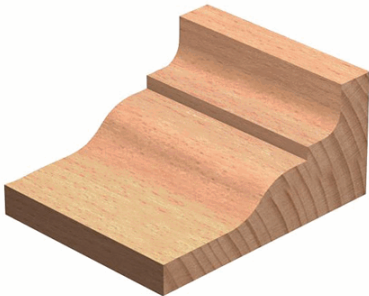

# Freeskoppen

4110

## MAN Bossingkop II

met HM wisselmessen

**Toepassing:** Geschikt voor het maken van 9 verschillende bossingprofielen in zacht- en hardhout en plaatmateriaal op een stationaire freesmachine.

**Uitvoering:** Slijtvaste aluminium kop, compleet met HM wisselmessen. De kop wordt standaard met 1 set messen naar keuze geleverd. Profiellengte ca. 60mm.



Bestelnr.	D	B	Z	d	rpm	P
4110.30A	180	25	2	30	4200-7000	A
4110.40A	180	25	2	40	4200-7000	A

### Toebehoren:

Bestelnr.	Omschrijving	is voor:
09.1104F	HM mes tbv 4110	A
09.1105F	HM mes tbv 4110	A
09.1130F	HM mes tbv 4110	A
09.1131F	HM mes tbv 4110	A
09.1132F	HM mes tbv 4110	A
09.1133F	HM mes tbv 4110	A
09.1134F	HM mes tbv 4110	A
09.1135F	HM mes tbv 4110	A
09.1136F	HM mes tbv 4110	A

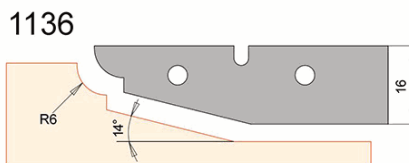
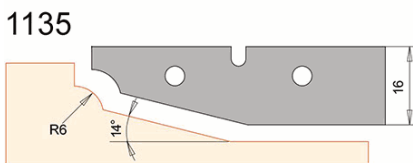
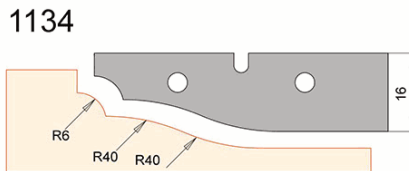
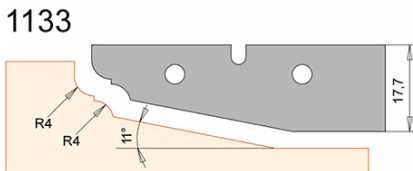
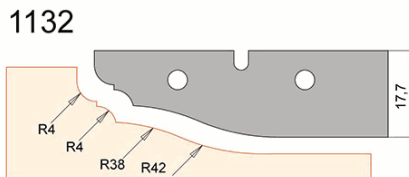
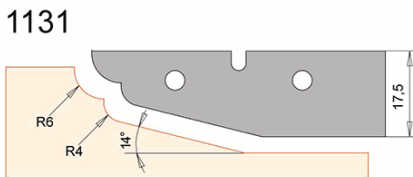
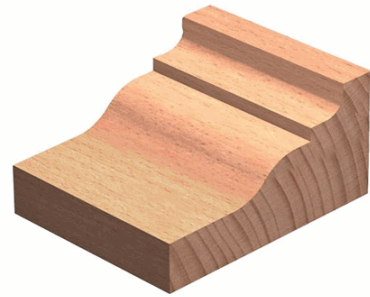
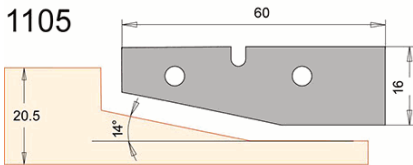
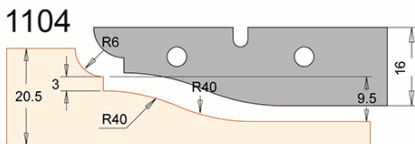

## Bossingkop III

met HM wisselmessen

**Toepassing:** Geschikt voor het maken van 6 verschillend bossingprofielen in zacht- en hardhout en plaatmateriaal op een stationaire freesmachine.

**Uitvoering:** Slijtvaste aluminium kop, compleet met HM wisselmessen. De kop wordt standaard met 1 set messen naar keuze geleverd. Profiellengte ca. 50mm.

Bestelnr.	D	B	Z	d	rpm	P
4130.30A	180	28	2	30	4200-7000	A

### Toebehoren:

Bestelnr.	Omschrijving	is voor:
09.1150F	HM mes tbv 4130	A
09.1151F	HM mes tbv 4130	A
09.1152F	HM mes tbv 4130	A
09.1153F	HM mes tbv 4130	A
09.1154F	HM mes tbv 4130	A
09.1155F	HM mes tbv 4130	A

MAN

4130

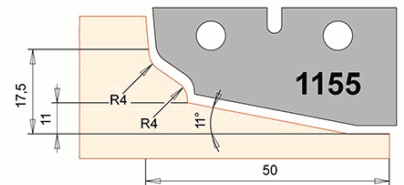
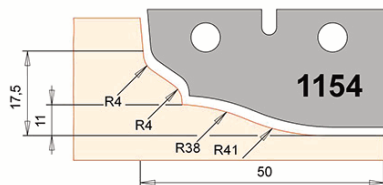
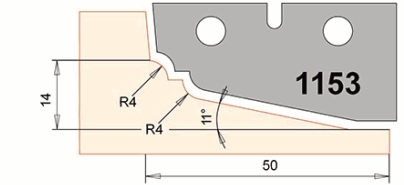
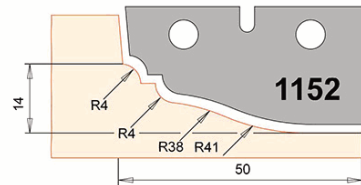
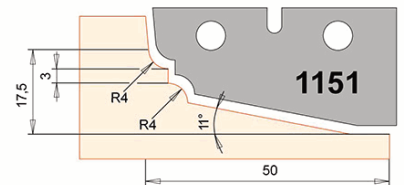
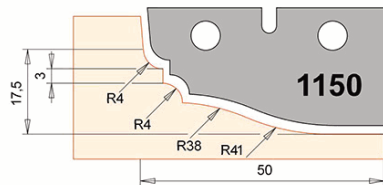
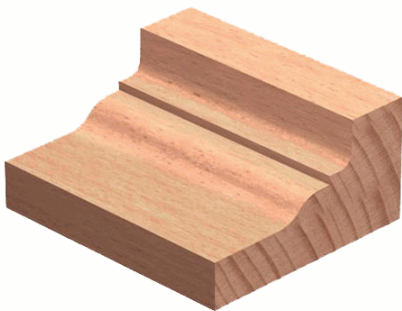

# Freeskoppen

4120

## MAN Bossingkop 4A

met HM wisselmessen

**Toepassing:** Geschikt voor het maken van een bossingprofiel in zacht- en hardhout en plaatmateriaal op een stationaire freesmachine.

**Uitvoering:** Slijtvaste aluminium kop, compleet met HM wisselmessen. Profiellengte ca. 60mm

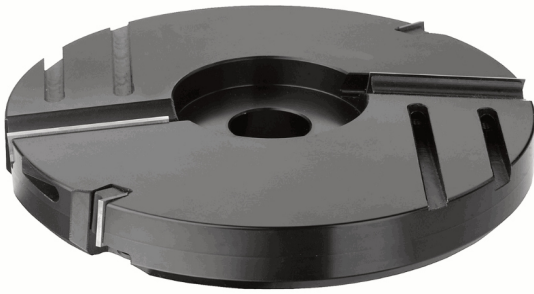

Bestelnr.	D	B	Z	d	rpm	P
4120.30A	200	35	2	30	3900-6600	A
4120.40A	200	35	2	40	3900-6600	A

### Toebehoren:

Bestelnr.	Omschrijving	is voor:
09.0025F	HM mes tbv 4120	A
09.0027F	HM mes tbv 4120	A

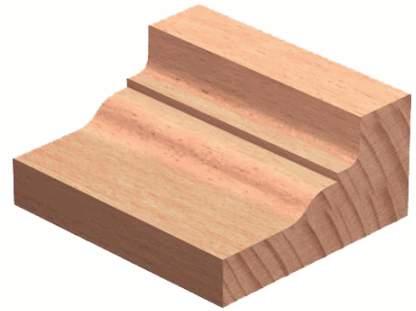
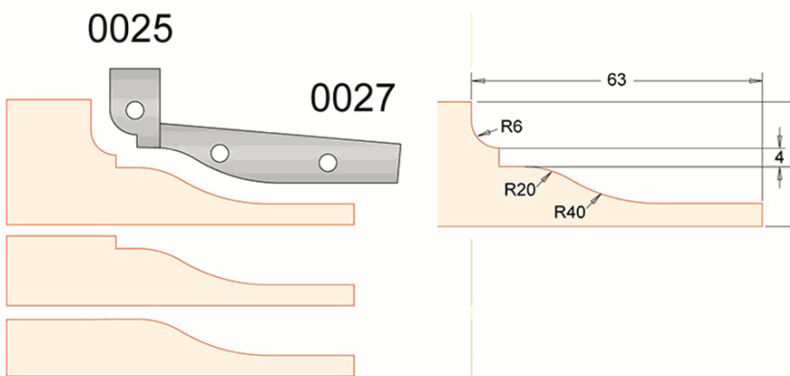

4121

## MAN Bossingkop 4B

met HM wisselmessen

**Toepassing:** Geschikt voor het maken van een bossingprofiel in zacht- en hardhout en plaatmateriaal op een stationaire freesmachine.

**Uitvoering:** Slijtvaste aluminium kop, compleet met HM wisselmessen. Profiellengte ca. 60mm

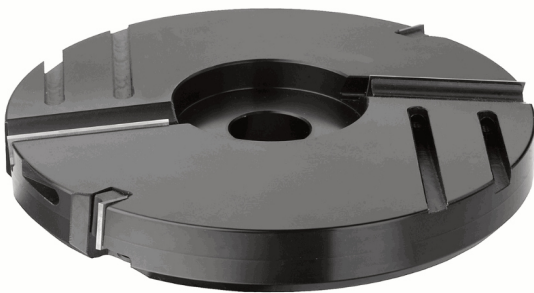

Bestelnr.	D	B	Z	d	rpm	P
4121.30A	200	35	2	30	3900-6600	A
4121.40A	200	35	2	40	3900-6600	A

### Toebehoren:

Bestelnr.	Omschrijving	is voor:
09.0026F	HM mes tbv 4121	A
09.0028F	HM mes tbv 4121	A

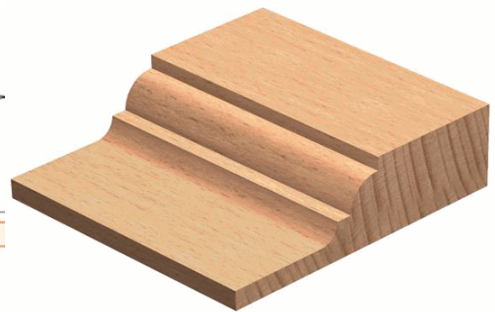
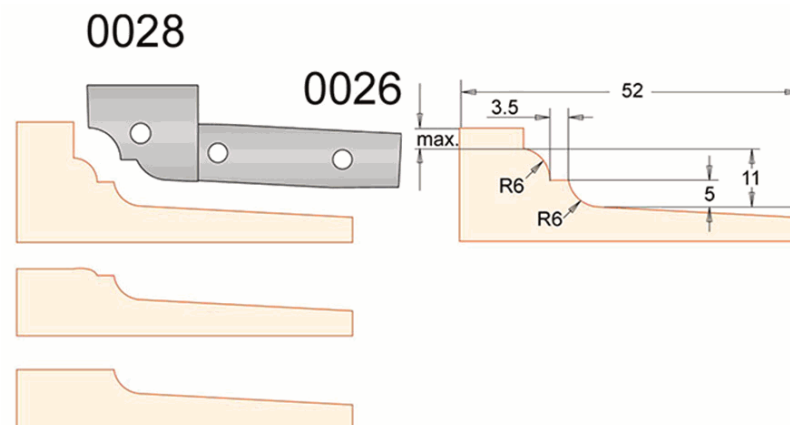

## Bossingkop 4C

met HM wisselmessen

**Toepassing:** Geschikt voor het maken van een bossingprofiel in zacht- en hardhout en plaatmateriaal op een stationaire freesmachine.

**Uitvoering:** Slijtvaste aluminium kop, compleet met HM wisselmessen. Profiellengte ca. 60mm.

Bestelnr.	D	B	Z	d	rpm	P
4122.30A	200	35	2	30	3900-6600	A
4122.40A	200	35	2	40	3900-6600	A

### Toebehoren:

Bestelnr.	Omschrijving	is voor:
L20	Mes 20x12x1,5/2sn	A
L60	60x12x1,5/2sn	A

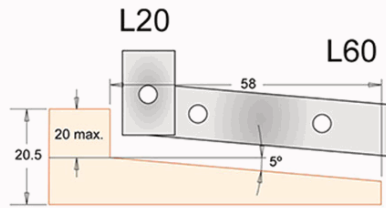
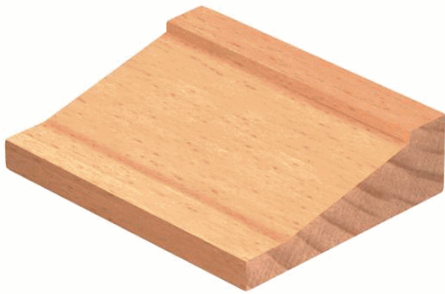

MAN

4122



## Bossingkop

met HM vaste messen

**Toepassing:** Geschikt voor het maken van een bossingprofiel in zacht- en hardhout en plaatmateriaal op een stationaire freesmachine.

**Uitvoering:** Slijtvaste stalen kop met HM messen. Profiellengte max 55mm

Bestelnr.	D	Z	R	d	rpm	P
4180.40S	160	2	8	30	max 9000	

MAN

4180

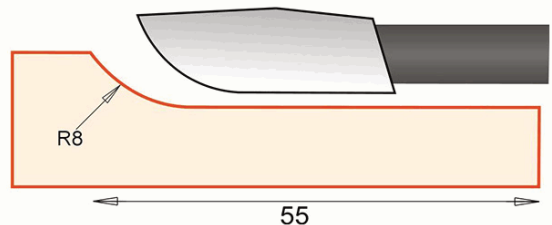

# Freeskoppen

3370

## MAN Uni Bossingkop



**Toepassing:** Voor het maken van bossingprofielen in zacht- en hardhout met de diverse profielmessen in de maten 50x4.

**Uitvoering:** Slijtvaste aluminium kop. De kop wordt geleverd zonder messen en keermessen. Er is keuze uit zeven verschillende bossingprofielen

Bestelnr.	D	B	Z	d	rpm	P
3370.30A	160	48	2	30	4500-7000	A
3370.40A	160	48	2	40	4500-7000	A

### Toebehoren:

Bestelnr.	Omschrijving	is voor:
50x4 Bossing	Zie pagina 64	A

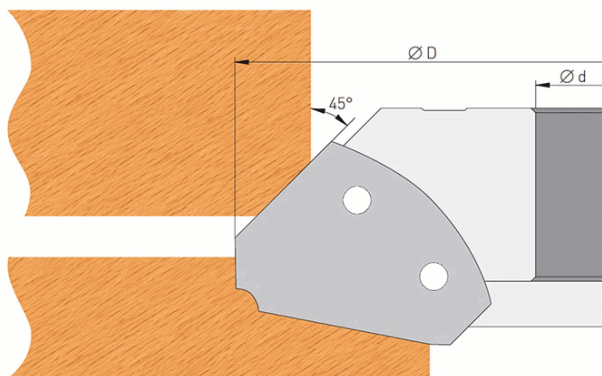

## Profielkoppen

### Profiel contra profiel bossing set

met HM vaste messen

**Toepassing:** Voor het frezen van profielen en contraprofielen ter vervaardiging van diverse raamwerken. Tevens voorzien van een bossingmes voor het vervaardigen van bossingprofielen. Het omstellen geschiedt door de volgorde van de freeskopdelen te wijzigen.

**Uitvoering:** Twee stalen freeskopdelen en ringen. Maat pen BxL:5x12mm. Lengte bossingprofiel: 45mm.

Bestelnr.	D	B	Z	d	rpm	P
4290.30S	160	27	2	30	max 9000	
4290.40S	160	27	2	40	max 8000	

MAN

4290

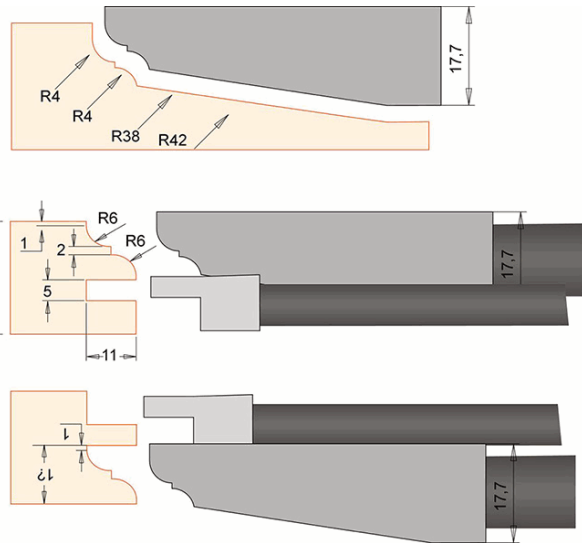
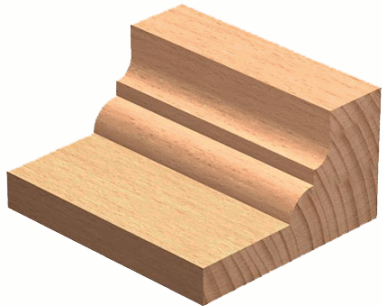

## Sets

### Freetskoppenset in houten kist

met HM wisselmessen

**Toepassing:** Voor het vervaardigen van paneeldeuren. Zowel het aanbrengen van een bossingprofiel met freeskop 4100 als het frezen van het profiel/contraprofiel met freeskop 4200 en het afwerken van de randen met een profiel met freeskop 4400.

**Uitvoering:** Zie pag 29, 33 en 34 voor de details van de individuele freeskoppen. Ook leverbaar op asgat 40mm.

Bestelnr.	D	B	Z	d	rpm	P
5010.30A				30		
Bevat:						
4400.30A	120	40	2	30	6400-10000	
4100.30A	160	20	2	30	4800-8000	
4200.30A	120	40	2	30	6400-8400	

MAN

5010

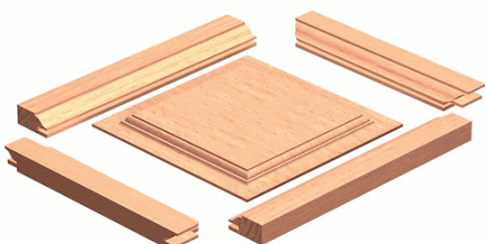

# Freeskoppen

## Multi ProfielSet 4270

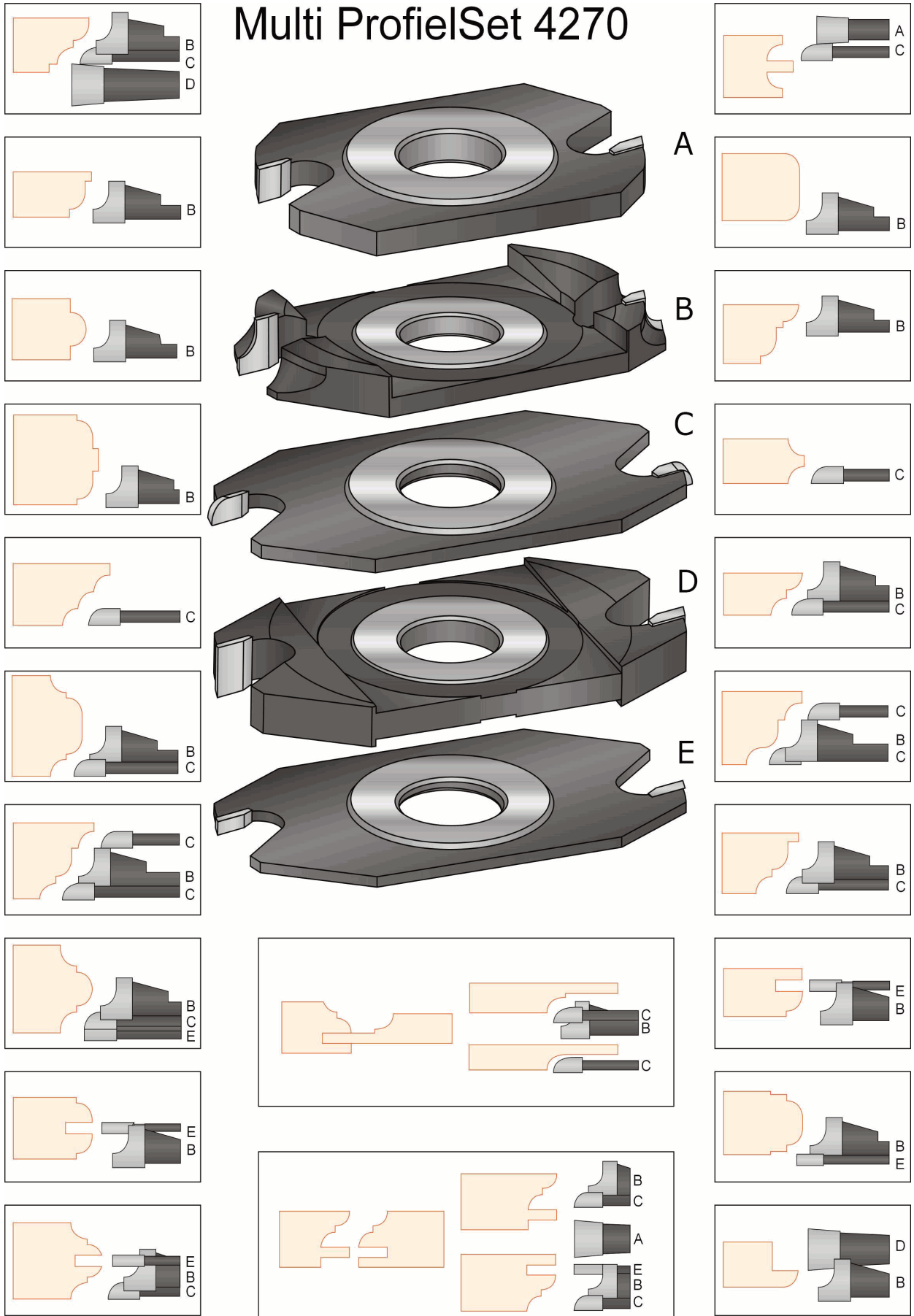



# Freeskoppen

## Multiprofielset

met HM vaste messen

**Toepassing:** Zeer veelzijdige set freesprofielen. Door slin variëren van de verschillende delen kan een groot aantal profielen gerealiseerd worden. (zie pag 40)

**Uitvoering:** In kunststof koffer met vijf freesdelen en ringenset.

Bestelnr.	D	Z	d	rpm	P
4270.40S	140	2	40	5500-9600	

MAN

4270

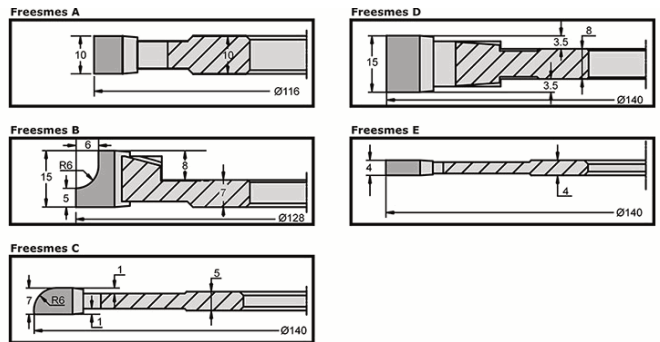

## Toebehoren voor freeskoppen en freesmessen

### Kisten

Voor 12, 24 en 36 paar messen

**Toepassing:** Voor het bewaren van een universeelkopme de bijbehorende messen en keermessen.

**Uitvoering:** Keurig afgewerkte houten kisten voor freeskoppen en bijbehorende messen.

Bestelnr.	P
5012	
5024	
5036	

5000



### Kunststof kist

Let op: Kist wordt leeg geleverd!

**Toepassing:** Voor het veilig bewaren van de freeskop me toebehoren.

**Uitvoering:** Sterke Kunststof koffer met universele indeling.

Bestelnr.	P
5018	

5050



# Freeskoppen

6900



## Kopieerringenset voor freeskoppen

**Toepassing:** Ideaal voor frezen langs een mal.

**Uitvoering:** Lager met verwisselbare aanloopringen. Hiermee kan men 4 verschillende maten buitendiameter verkrijgen: 85-90-95 en 100 mm.

Bestelnr.	d	P
6900.30S	30	
6900.40S	40	

6910



## Uitvulringenset

**Toepassing:** Uitvulringen voor het met 0,1 mm stapsgewijs uitvullen van freeskopdelen.

**Uitvoering:** Set van 12 ringen van 0,1/0,2/0,3/3,4 en 6,4mm.

Bestelnr.	D	B	d	P
6910			30	
6911			40	
6910ring01	45	0.1	4	30
6910ring02	45	0.2	4	30
6910ring03	45	0.3	2	30
6910ring34	45	3.4	1	30
6910ring64	45	6.4	1	30

6920



## Verloopringenset

**Toepassing:** Maakt het mogelijk om freeskoppen met asgat 40mm toe te passen op een as van 30mm.

**Uitvoering:** Twee pasbussen met flens voor het aanbrengen aan de boven- en onderzijde van de freeskop

Bestelnr.	D	d	P
6920	40	30	





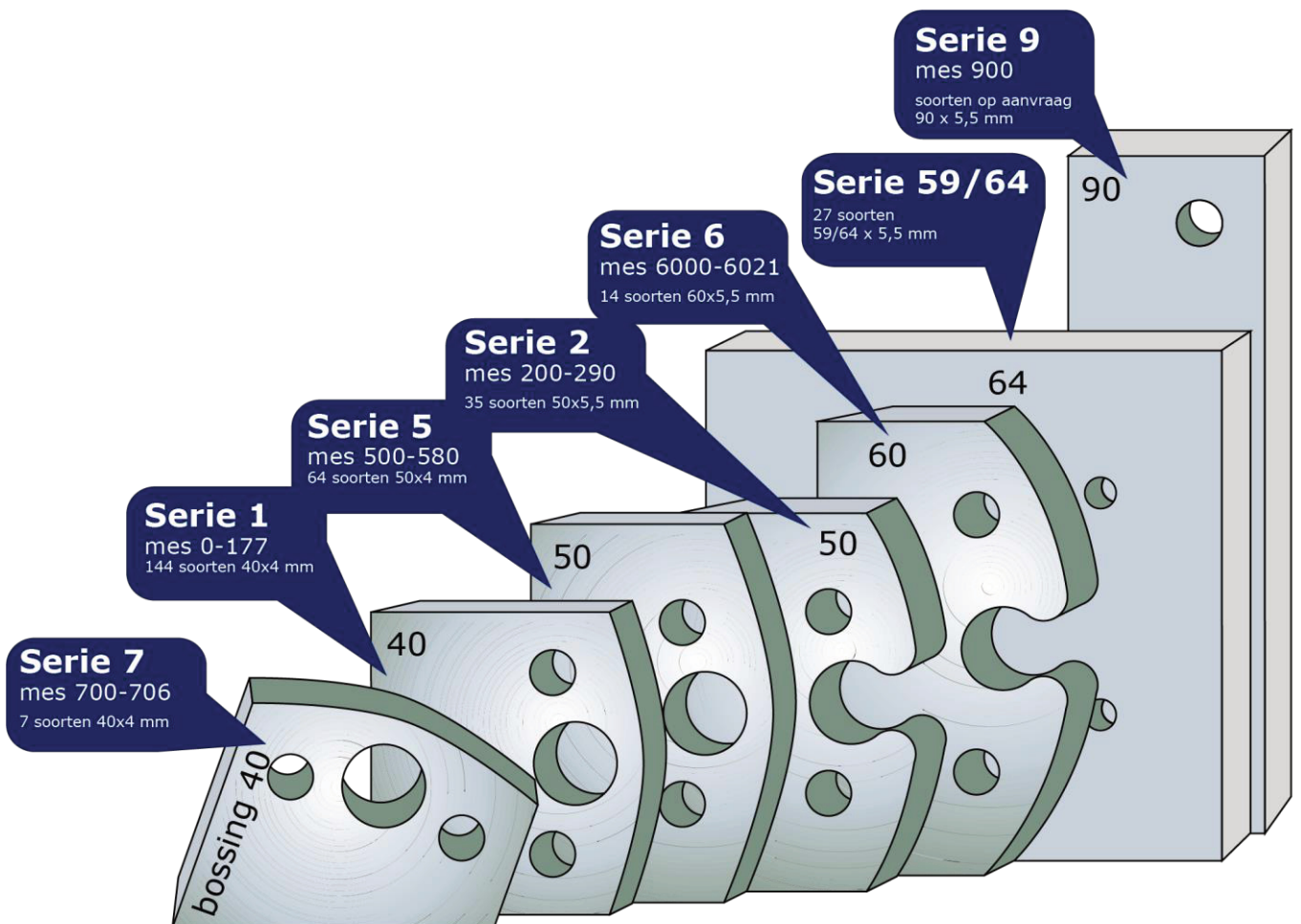
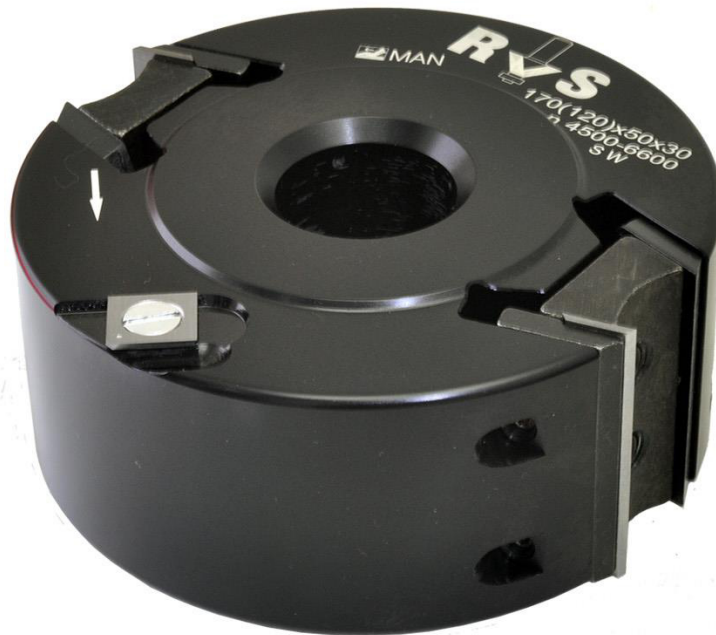

# Universeelmessen

## Universeel freeskoppen

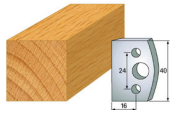

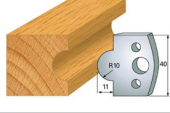
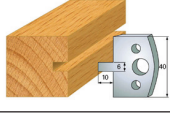
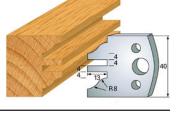
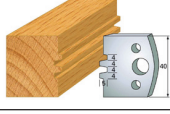
# Universeelmessen

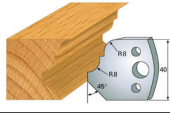
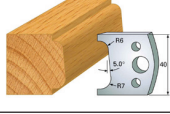
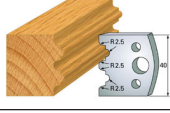
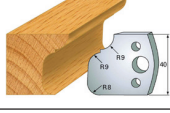
## Freesmessenselector

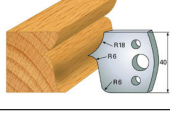
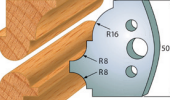
PROFIELSOORT	VOORBEELDMES	MESSEN
<b>Rechte messen</b>		0, 1, 127, 500
<b>Afrondprofielen</b>		3, 4, 5, 15, 40, 50, 51, 62, 66, 69, 90, 115, 119, 136, 170, 172, 173, 174, 175, 176, 177
<b>Convex/Bol Concaaf/hol profielen</b>		10, 14, 30, 58, 65, 87, 93, 118, 131, 543, 544, 545, 546, 547, 548, 549, 553, 554, 555, 556, 559, 560, 561, 562, 563, 564, 565, 566, 567, 569, 573, 574
<b>Messing en groef</b>		16, 17, 34, 35, 71, 72, 83, 84, 85, 86, 91, 92, 94, 95, 113, 114
<b>Raamwerken</b>		55, 79, 89, 96, 97, 98, 99, 100, 134, 522&523, 568, 570, 579, 577
<b>Verlijmen</b>		27, 28, 74, 75, 76, 77, 117, 524, 552, 572, 576
<b>Handgrepen</b>		9, 56, 120, 504, 514, 550, 570, 571, 575
<b>Klassieke profielen</b>		12, 19, 20, 21, 22, 26, 31, 37, 39, 42, 53, 54, 67, 73, 125, 126, 132, 133
<b>Tafelranden</b>		2, 5, 8, 32, 38, 70, 130
<b>Plankranden</b>		18, 23, 25, 36, 80, 108
<b>Ogieprofielen</b>		11, 13, 41, 43, 44, 45, 47, 48, 49, 51, 57, 59, 60, 64, 68, 82, 112, 129
<b>Kroonlijsten</b>		24, 29, 33, 36, 52, 81, 101, 102, 103, 104, 105, 106, 107, 109, 110, 111, 122, 123, 501, 502, 503, 506, 507, 08, 509, 510, 511, 512, 513, 519, 578
<b>Free Style</b>		46, 78, 116, 128, 135, 505, 516, 517, 518
<b>Multi-Profiel</b>		515, 520, 541, 542, 551, 557, 558, 569

# Universeelmessen

## messen en keermessen 40x4

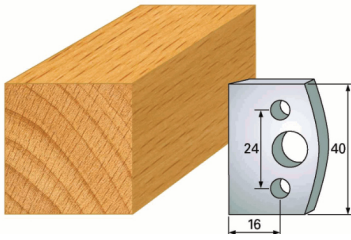

**Freesmes.**  
M0  
M0-HSS  
M0-KORT

**Keermes**  
A0  
A0-KORT  
A0-LANG

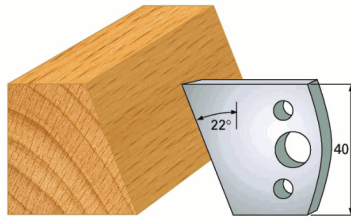

**Freesmes.**  
M1  
M1-ANDERSOM

**Keermes**  
A1  
A1-ANDERSOM

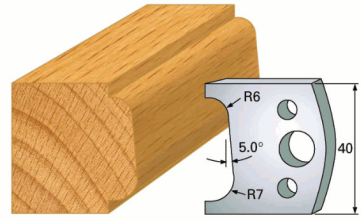

**Freesmes.**  
M2

**Keermes**  
A2

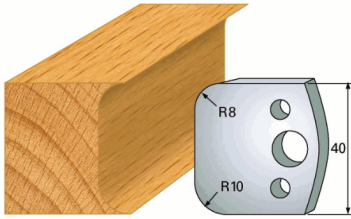

**Freesmes.**  
M3

**Keermes**  
A3

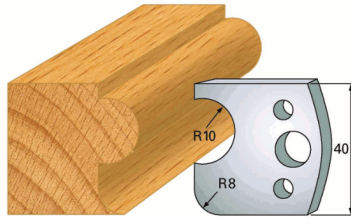

**Freesmes.**  
M4

**Keermes**  
A4

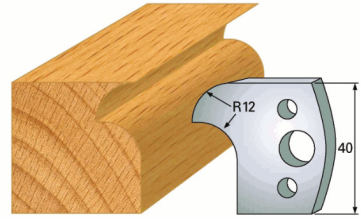

**Freesmes.**  
M5

**Keermes**  
A5

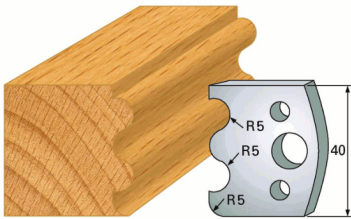

**Freesmes.**  
M6

**Keermes**  
A6

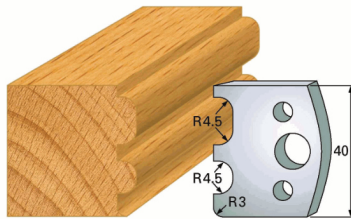

**Freesmes.**  
M7

**Keermes**  
A7

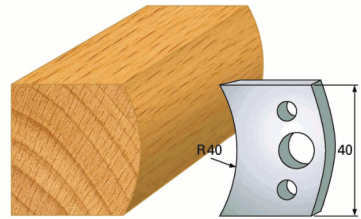

**Freesmes.**  
M8

**Keermes**  
A8

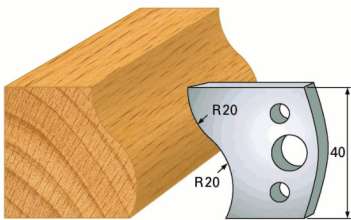

**Freesmes.**  
M9

**Keermes**  
A9

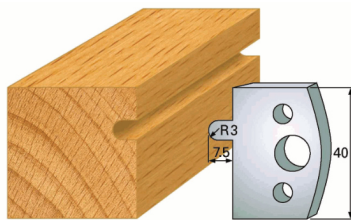

**Freesmes.**  
M10

**Keermes**  
A10

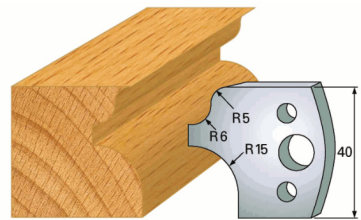

**Freesmes.**  
M11

**Keermes**  
A11

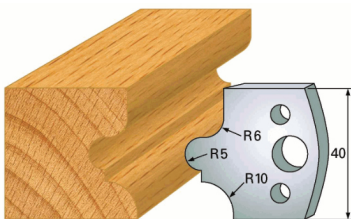

**Freesmes.**  
M12

**Keermes**  
A12

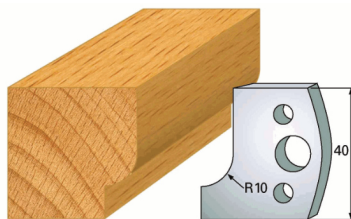

**Freesmes.**  
M13

**Keermes**  
A13

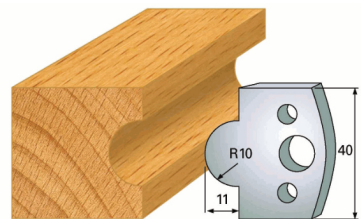

**Freesmes.**  
M14

**Keermes**  
A14

# Universeelmessen

## messen en keermessen 40x4

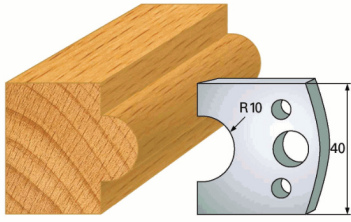

**Freemes.**  
M15

**Keemes**  
A15

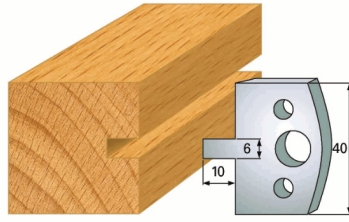

**Freemes.**  
M16  
M16HM

**Keemes**  
A16

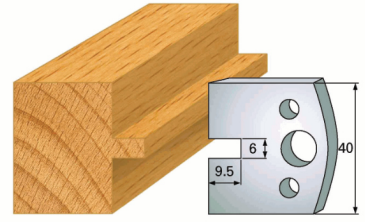

**Freemes.**  
M17  
M17HM

**Keemes**  
A17

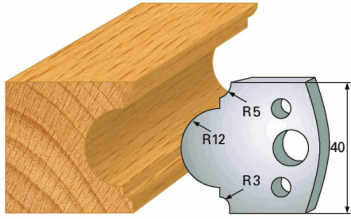

**Freemes.**  
M18

**Keemes**  
A18

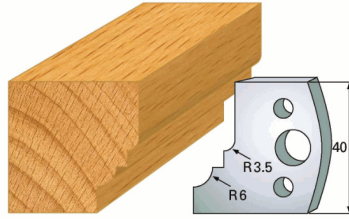

**Freemes.**  
M19

**Keemes**  
A19

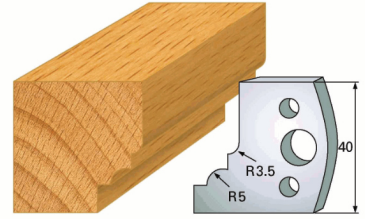

**Freemes.**  
M20

**Keemes**  
A20

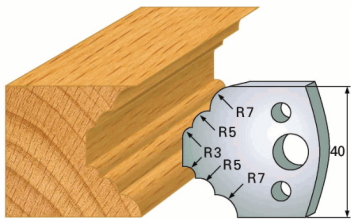

**Freemes.**  
M21

**Keemes**  
A21

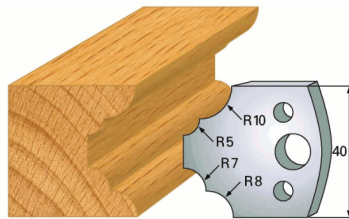

**Freemes.**  
M22

**Keemes**  
A22

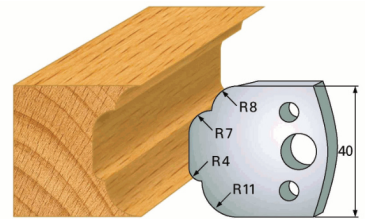

**Freemes.**  
M23

**Keemes**  
A23

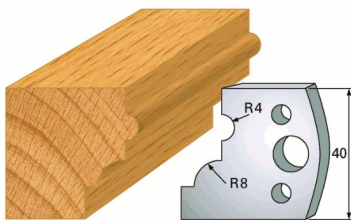

**Freemes.**  
M24

**Keemes**  
A24

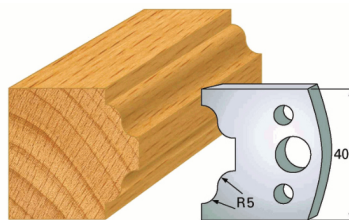

**Freemes.**  
M25

**Keemes**  
A25

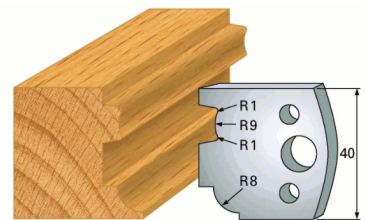

**Freemes.**  
M26

**Keemes**  
A26

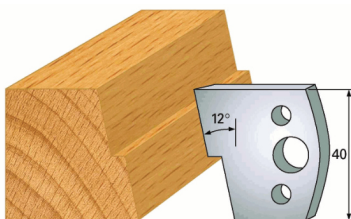

**Freemes.**  
M27

**Keemes**  
A27

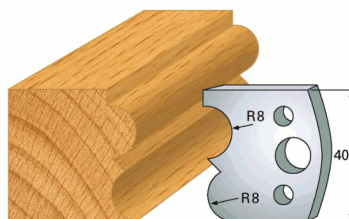

**Freemes.**  
M28

**Keemes**  
A28

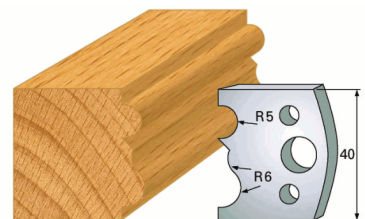

**Freemes.**  
M29

**Keemes**  
A29

# Universeelmessen messen en keermessen 40x4

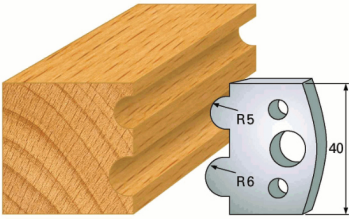

**Freesmes.**  
M30

**Keermes**  
A30

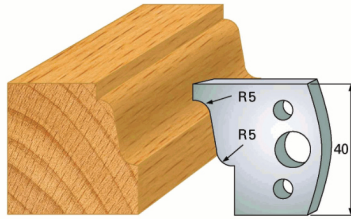

**Freesmes.**  
M31

**Keermes**  
A31

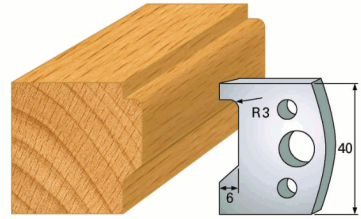

**Freesmes.**  
M32

**Keermes**  
A32

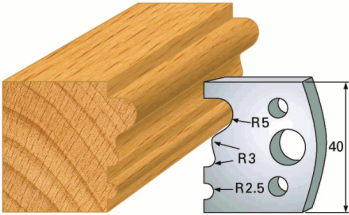

**Freesmes.**  
M33

**Keermes**  
A33

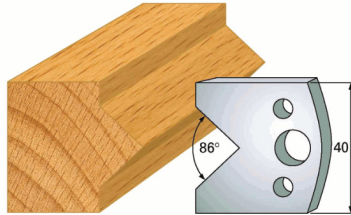

**Freesmes.**  
M34

**Keermes**  
A34

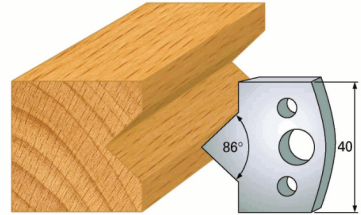

**Freesmes.**  
M35

**Keermes**  
A35

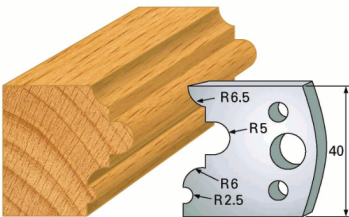

**Freesmes.**  
M36

**Keermes**  
A36

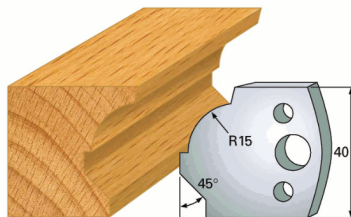

**Freesmes.**  
M37

**Keermes**  
A37

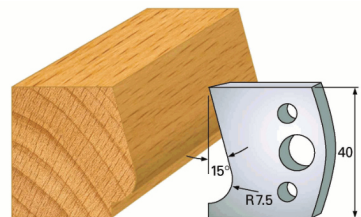

**Freesmes.**  
M38

**Keermes**  
A38

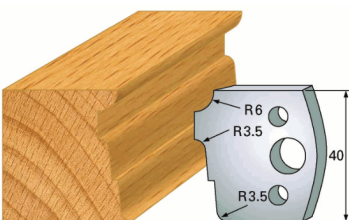

**Freesmes.**  
M39

**Keermes**  
A39

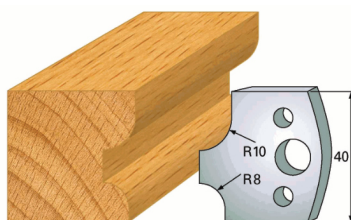

**Freesmes.**  
M40

**Keermes**  
A40

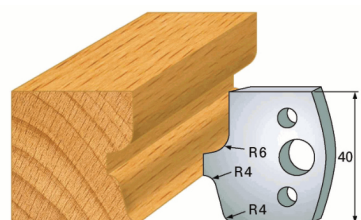

**Freesmes.**  
M41

**Keermes**  
A41

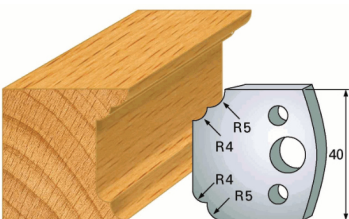

**Freesmes.**  
M42

**Keermes**  
A42

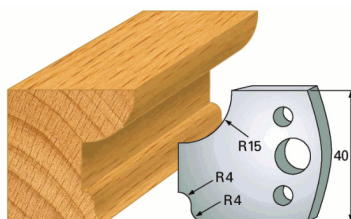

**Freesmes.**  
M43

**Keermes**  
A43

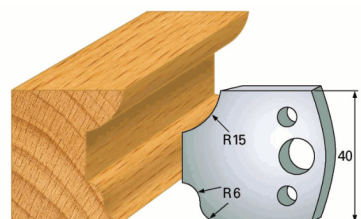

**Freesmes.**  
M44

**Keermes**  
A44

# Universeelmessen

## messen en keermessen 40x4

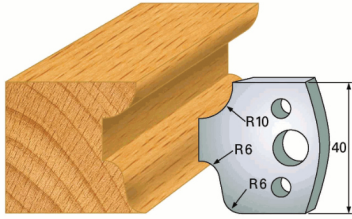

**Freesmes.**  
M45

**Keermes**  
A45

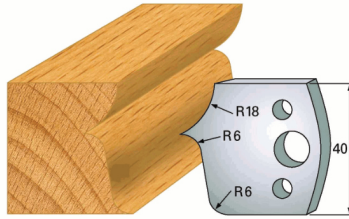

**Freesmes.**  
M46

**Keermes**  
A46

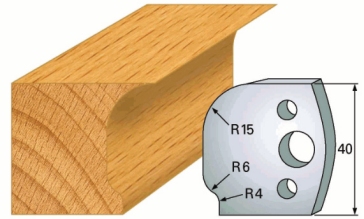

**Freesmes.**  
M47

**Keermes**  
A47

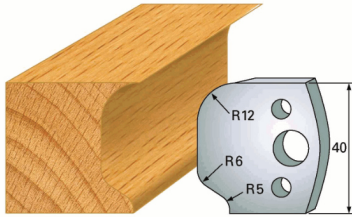

**Freesmes.**  
M48

**Keermes**  
A48

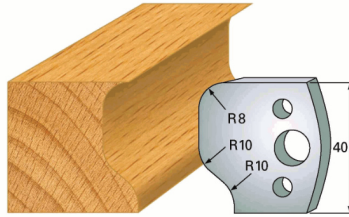

**Freesmes.**  
M49

**Keermes**  
A49

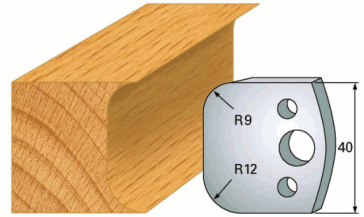

**Freesmes.**  
M50

**Keermes**  
A50

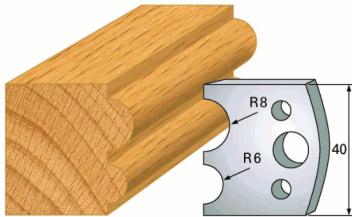

**Freesmes.**  
M51

**Keermes**  
A51

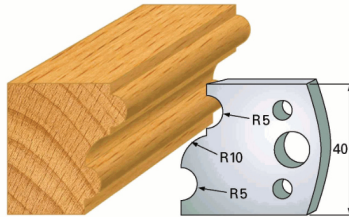

**Freesmes.**  
M52

**Keermes**  
A52

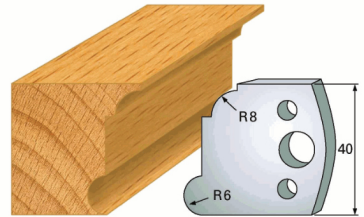

**Freesmes.**  
M53

**Keermes**  
A53

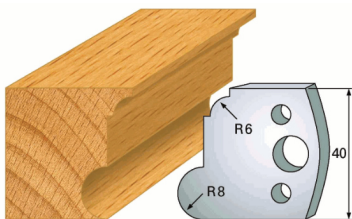

**Freesmes.**  
M54

**Keermes**  
A54

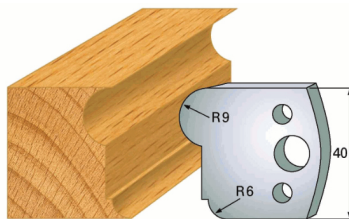

**Freesmes.**  
M55

**Keermes**  
A55

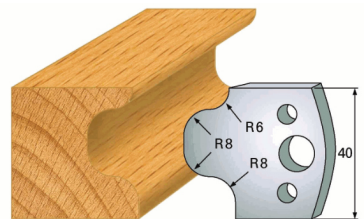

**Freesmes.**  
M56

**Keermes**  
A56

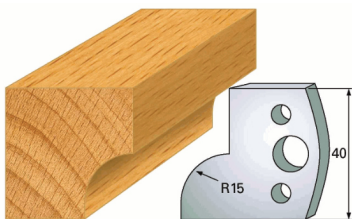

**Freesmes.**  
M57

**Keermes**  
A57

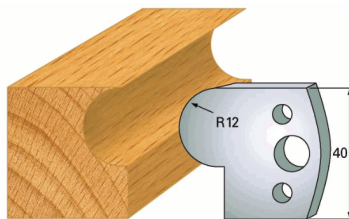

**Freesmes.**  
M58

**Keermes**  
A58

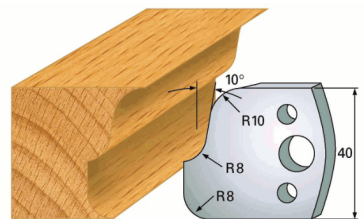

**Freesmes.**  
M59

**Keermes**  
A59



# Universeelmessen messen en keermessen 40x4

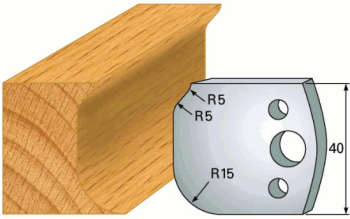

**Freesmes.**  
M60

**Keermes**  
A60

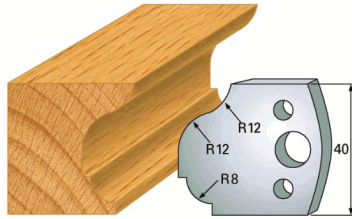

**Freesmes.**  
M61

**Keermes**  
A61

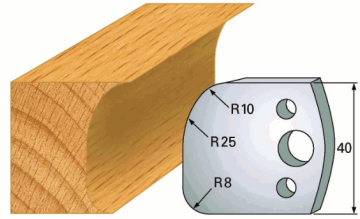

**Freesmes.**  
M62

**Keermes**  
A62

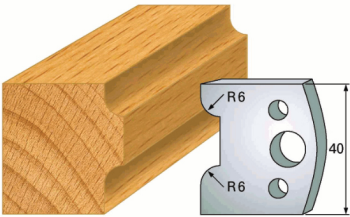

**Freesmes.**  
M63

**Keermes**  
A63

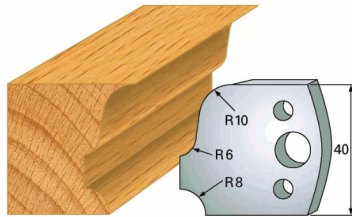

**Freesmes.**  
M64

**Keermes**  
A64

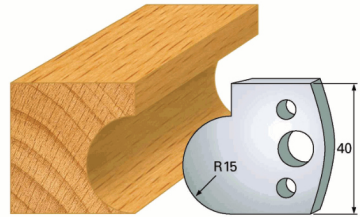

**Freesmes.**  
M65

**Keermes**  
A65

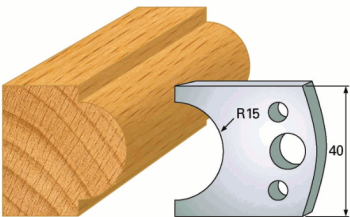

**Freesmes.**  
M66

**Keermes**  
A66

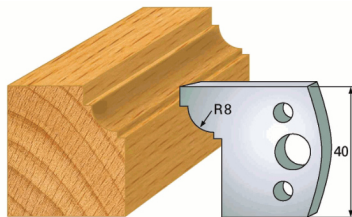

**Freesmes.**  
M67

**Keermes**  
A67

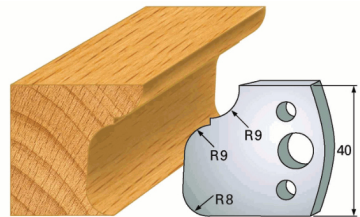

**Freesmes.**  
M68

**Keermes**  
A68

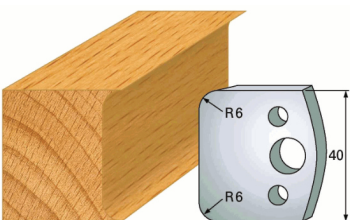

**Freesmes.**  
M69

**Keermes**  
A69

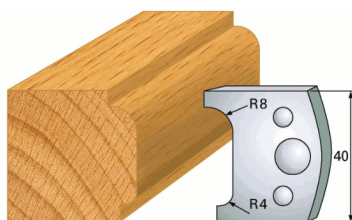

**Freesmes.**  
M70

**Keermes**  
A70

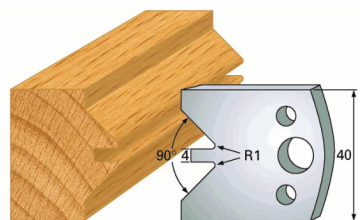

**Freesmes.**  
M71

**Keermes**  
A71

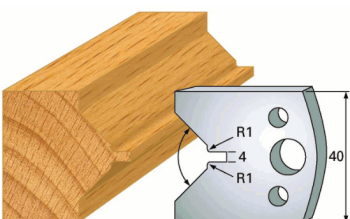

**Freesmes.**  
M72

**Keermes**  
A72

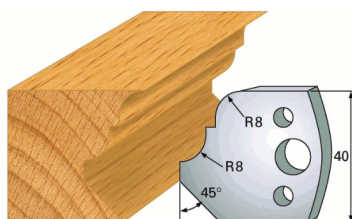

**Freesmes.**  
M73

**Keermes**  
A73

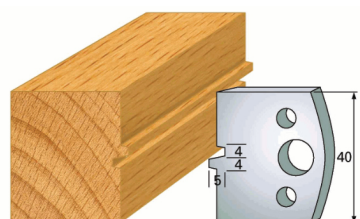

**Freesmes.**  
M74

**Keermes**  
A74

# Universeelmessen

## messen en keermessen 40x4

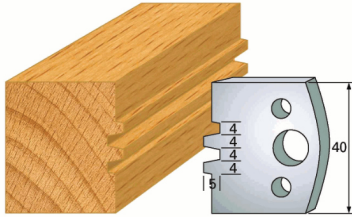

**Freesmes.**  
M75

**Keermes**  
A75

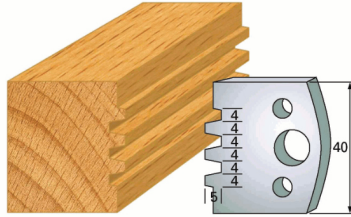

**Freesmes.**  
M76

**Keermes**  
A76

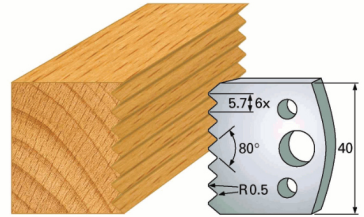

**Freesmes.**  
M77

**Keermes**  
A77

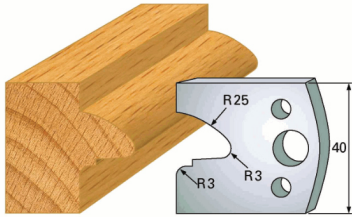

**Freesmes.**  
M78

**Keermes**  
A78

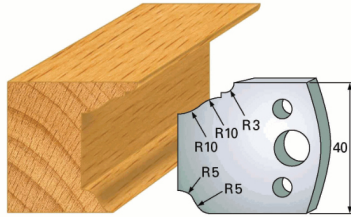

**Freesmes.**  
M79

**Keermes**  
A79

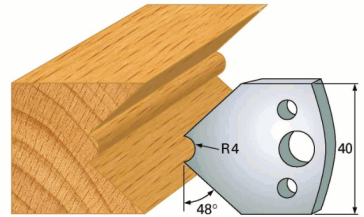

**Freesmes.**  
M80

**Keermes**  
A80

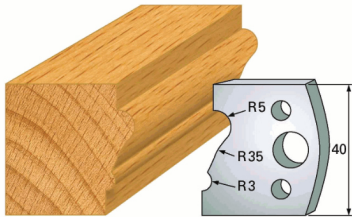

**Freesmes.**  
M81

**Keermes**  
A81

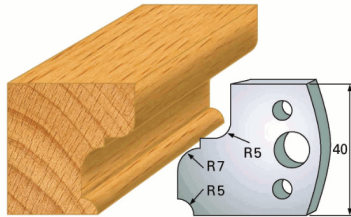

**Freesmes.**  
M82

**Keermes**  
A82

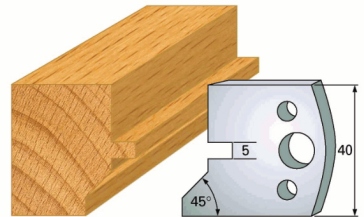

**Freesmes.**  
M83

**Keermes**  
A83

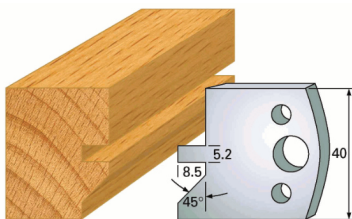

**Freesmes.**  
M84

**Keermes**  
A84

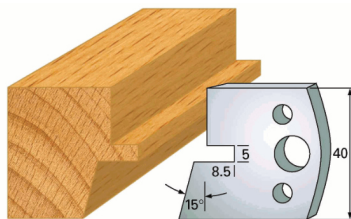

**Freesmes.**  
M85

**Keermes**  
A85

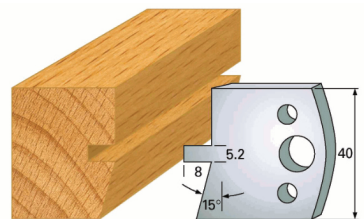

**Freesmes.**  
M86

**Keermes**  
A86

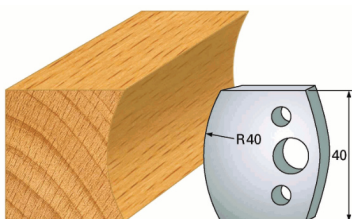

**Freesmes.**  
M87

**Keermes**  
A87

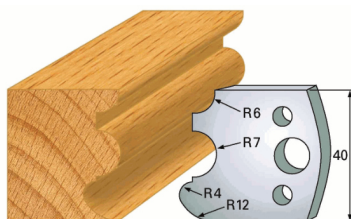

**Freesmes.**  
M88

**Keermes**  
A88

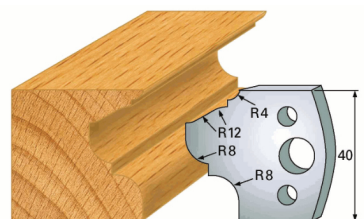

**Freesmes.**  
M89

**Keermes**  
A89

# Universeelmessen messen en keermessen 40x4

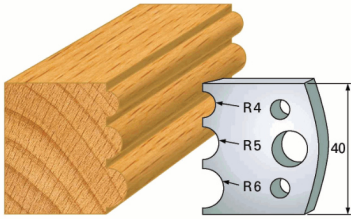

**Freesmes.**  
M90

**Keermes**  
A90

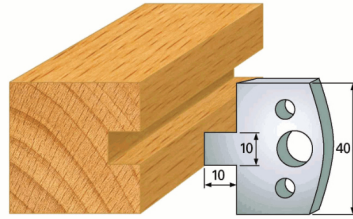

**Freesmes.**  
M91  
M91HM

**Keermes**  
A91

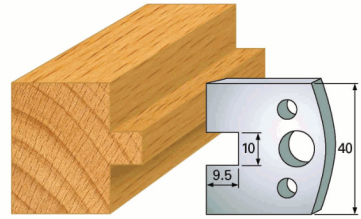

**Freesmes.**  
M92  
M92HM

**Keermes**  
A92

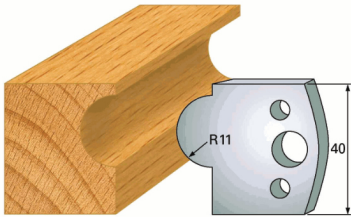

**Freesmes.**  
M93

**Keermes**  
A93

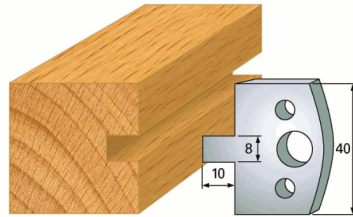

**Freesmes.**  
M94

**Keermes**  
A94

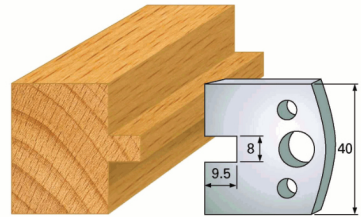

**Freesmes.**  
M95

**Keermes**  
A95

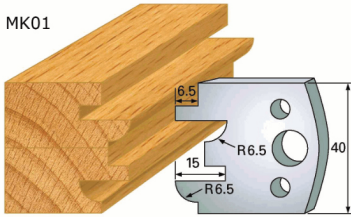

**Freesmes.**  
MK01/M96  
MK01HSS

**Keermes**  
AK01/A96

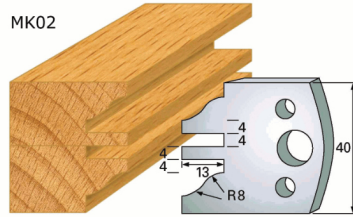

**Freesmes.**  
MK02/M97  
MK02HSS  
MK02HM

**Keermes**  
AK02/A97

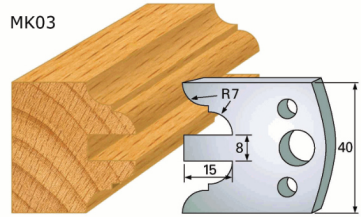

**Freesmes.**  
MK03/M98  
MK03HSS

**Keermes**  
AK03/A98

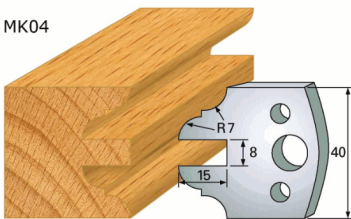

**Freesmes.**  
MK04/M99  
MK04HSS

**Keermes**  
AK04/A99

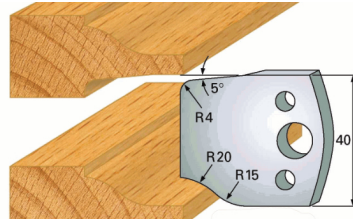

**Freesmes.**  
M100  
M100HSS  
M100HM

**Keermes**  
A100

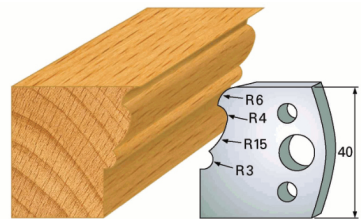

**Freesmes.**  
M101

**Keermes**  
A101

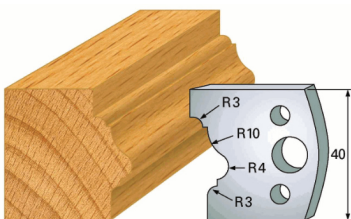

**Freesmes.**  
M102

**Keermes**  
A102

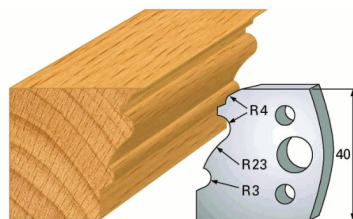

**Freesmes.**  
M103

**Keermes**  
A103

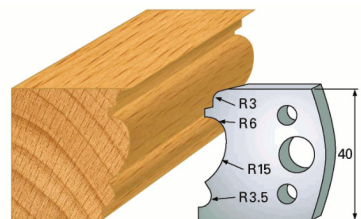

**Freesmes.**  
M104

**Keermes**  
A104

# Universeelmessen

## messen en keermessen 40x4

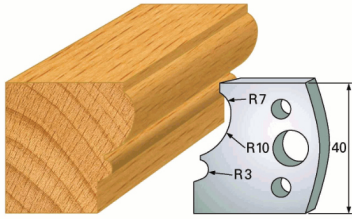

**Freesmes.**  
M105

**Keermes**  
A105

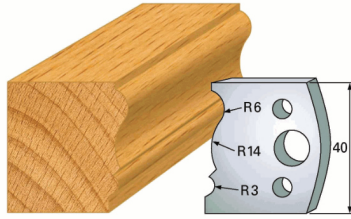

**Freesmes.**  
M106

**Keermes**  
A106

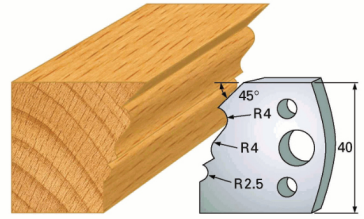

**Freesmes.**  
M107

**Keermes**  
A107

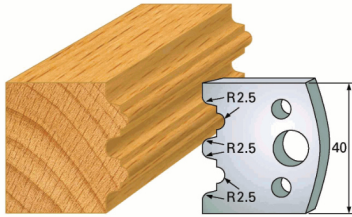

**Freesmes.**  
M108

**Keermes**  
A108

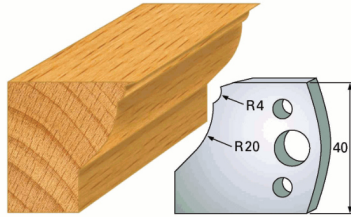

**Freesmes.**  
M109

**Keermes**  
A109

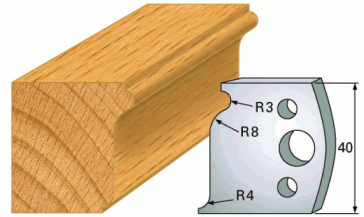

**Freesmes.**  
M110

**Keermes**  
A110

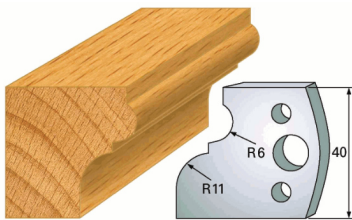

**Freesmes.**  
M111

**Keermes**  
A111

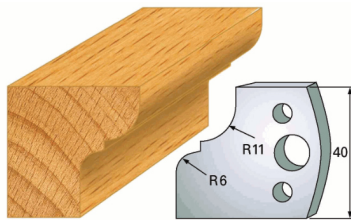

**Freesmes.**  
M112

**Keermes**  
A112

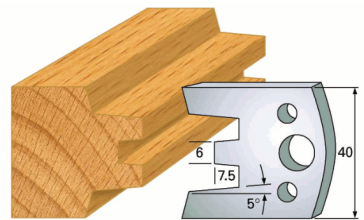

**Freesmes.**  
M113

**Keermes**  
A113

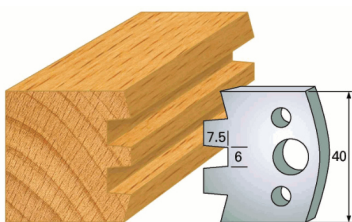

**Freesmes.**  
M114

**Keermes**  
A114

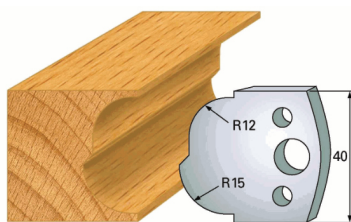

**Freesmes.**  
M115

**Keermes**  
A115

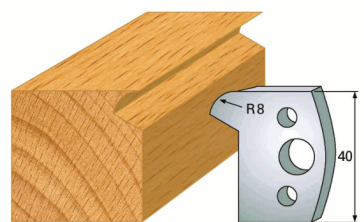

**Freesmes.**  
M116

**Keermes**  
A116

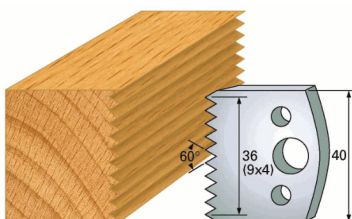

**Freesmes.**  
M117

**Keermes**  
A117

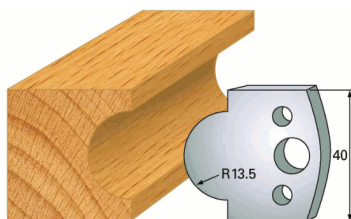

**Freesmes.**  
M118

**Keermes**  
A118

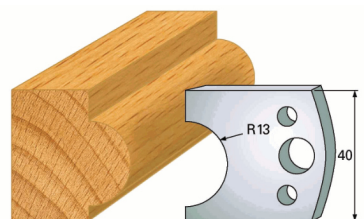

**Freesmes.**  
M119

**Keermes**  
A119

# Universeelmessen messen en keermessen 40x4

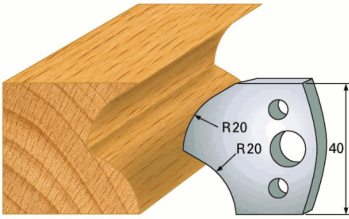

**Freesmes.**  
M120

**Keermes**  
A120

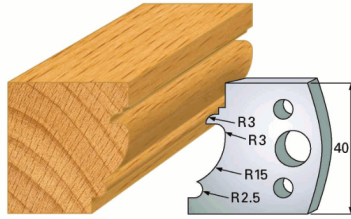

**Freesmes.**  
M121

**Keermes**  
A121

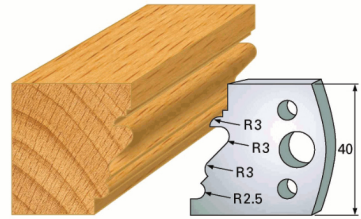

**Freesmes.**  
M122

**Keermes**  
A122

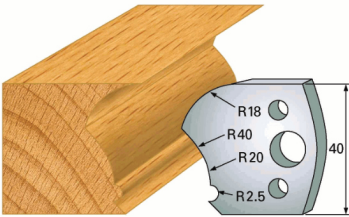

**Freesmes.**  
M123

**Keermes**  
A123

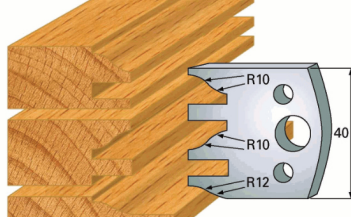

**Freesmes.**  
M124

**Keermes**  
A124

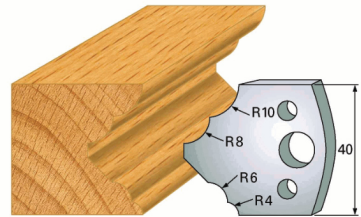

**Freesmes.**  
M125

**Keermes**  
A125

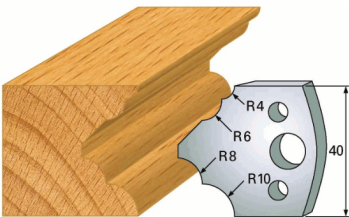

**Freesmes.**  
M126

**Keermes**  
A126

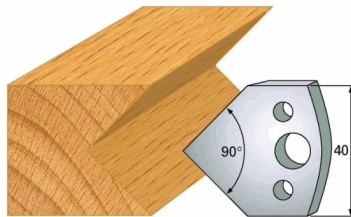

**Freesmes.**  
M127

**Keermes**  
A127

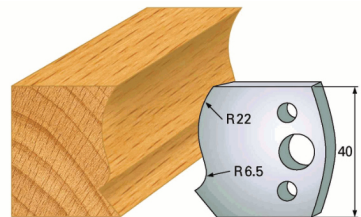

**Freesmes.**  
M128

**Keermes**  
A128

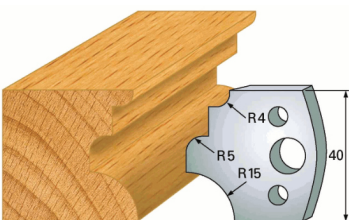

**Freesmes.**  
M129

**Keermes**  
A129

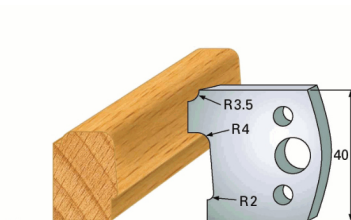

**Freesmes.**  
M130

**Keermes**  
A130

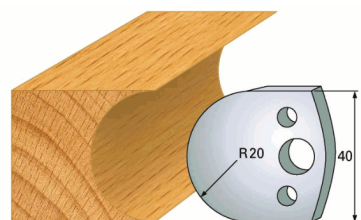

**Freesmes.**  
M131

**Keermes**  
A131

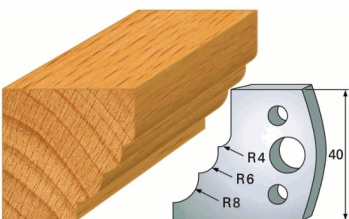

**Freesmes.**  
M132

**Keermes**  
A132

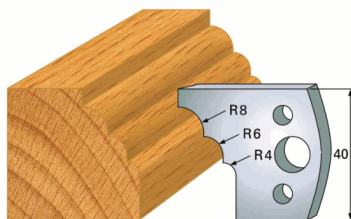

**Freesmes.**  
M133

**Keermes**  
A133

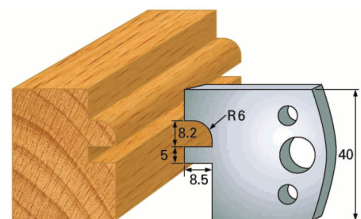

**Freesmes.**  
M134

**Keermes**  
A134

# Universeelmessen

## messen en keermessen 40x4

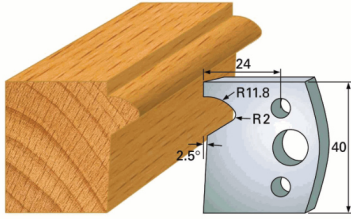

**Freesmes.**  
M135

**Keermes**  
A135

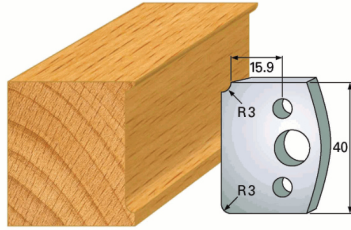

**Freesmes.**  
M170

**Keermes**  
A170

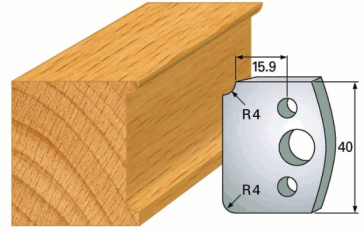

**Freesmes.**  
M171

**Keermes**  
A171

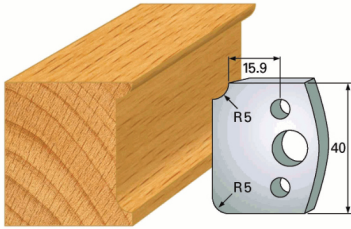

**Freesmes.**  
M172

**Keermes**  
A172

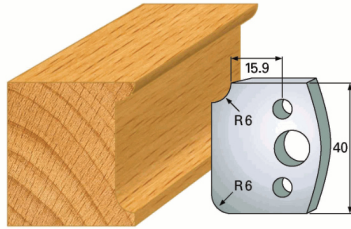

**Freesmes.**  
M173

**Keermes**  
A173

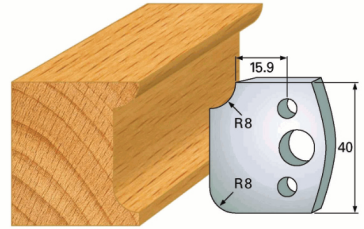

**Freesmes.**  
M174

**Keermes**  
A174

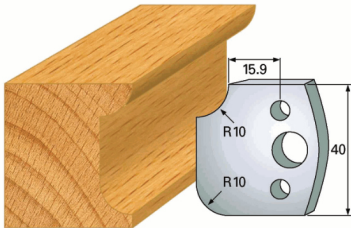

**Freesmes.**  
M175

**Keermes**  
A175

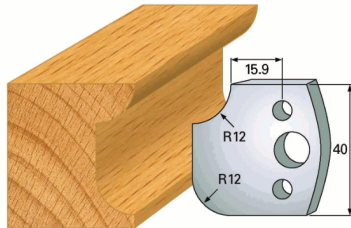

**Freesmes.**  
M176

**Keermes**  
A176

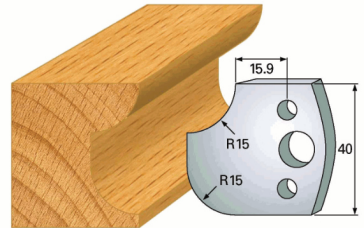

**Freesmes.**  
M177

**Keermes**  
A177

# Universeelmessen messen en keermessen 50x4

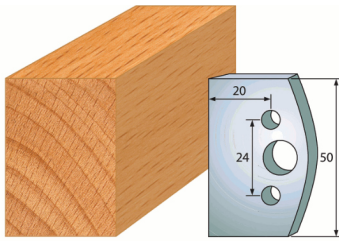

**Freesmes.**  
M500  
M5190/M5500HS

**Keermes**  
A5190/A500

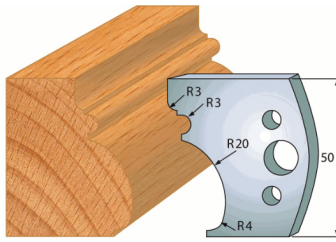

**Freesmes.**  
M501

**Keermes**  
A501

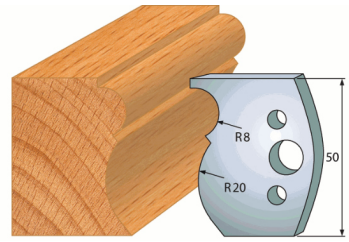

**Freesmes.**  
M502

**Keermes**  
A502

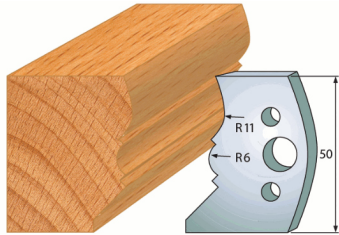

**Freesmes.**  
M503

**Keermes**  
A503

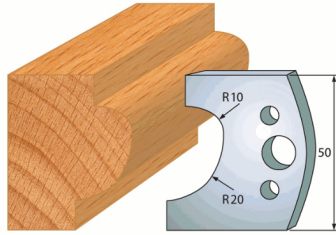

**Freesmes.**  
M504

**Keermes**  
A504

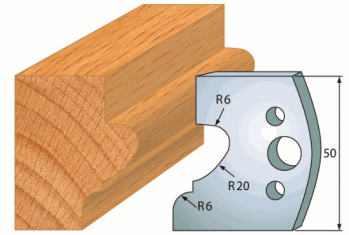

**Freesmes.**  
M505

**Keermes**  
A505

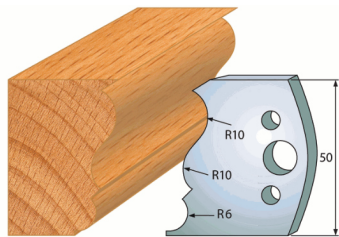

**Freesmes.**  
M506

**Keermes**  
A506

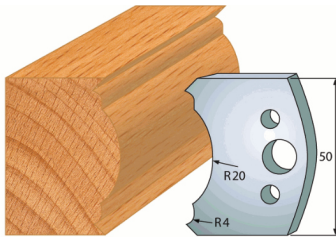

**Freesmes.**  
M507

**Keermes**  
A507

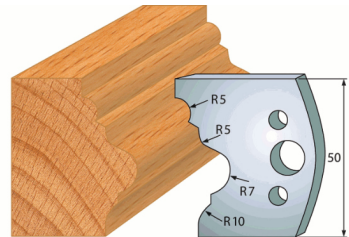

**Freesmes.**  
M508

**Keermes**  
A508

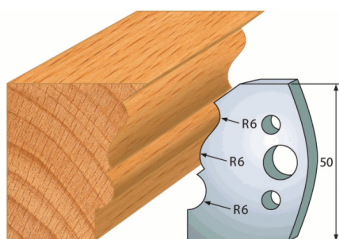

**Freesmes.**  
M509

**Keermes**  
A509

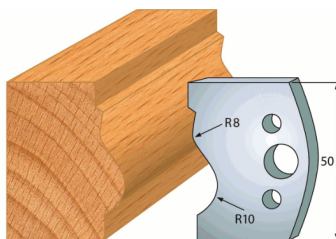

**Freesmes.**  
M510

**Keermes**  
A510

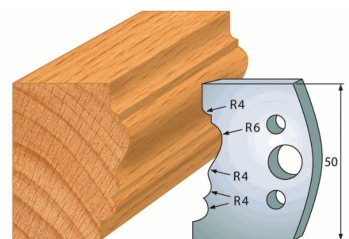

**Freesmes.**  
M511

**Keermes**  
A511

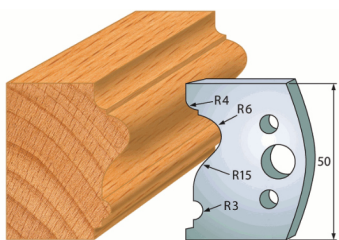

**Freesmes.**  
M512

**Keermes**  
A512

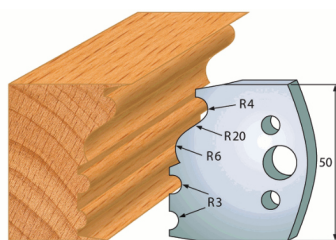

**Freesmes.**  
M513

**Keermes**  
A513

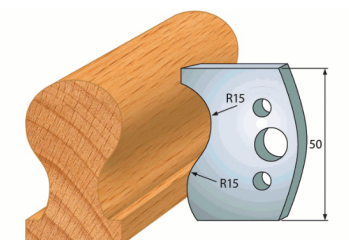

**Freesmes.**  
M514

**Keermes**  
A514

# Universeelmessen

## messen en keermessen 50x4

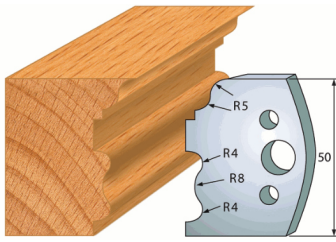

**Freesmes.**  
M515

**Keermes**  
A515

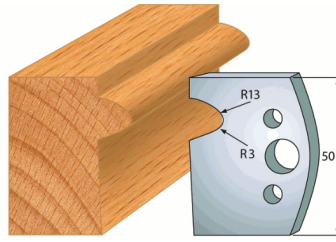

**Freesmes.**  
M516

**Keermes**  
A516

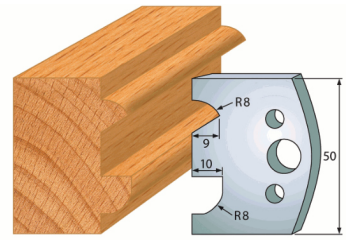

**Freesmes.**  
M517

**Keermes**  
A517

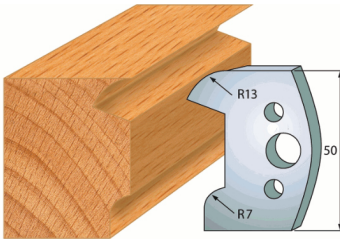

**Freesmes.**  
M518

**Keermes**  
A518

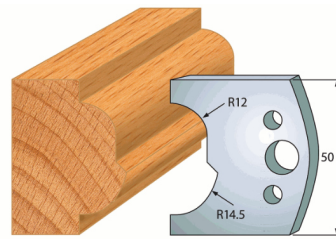

**Freesmes.**  
M519

**Keermes**  
A519

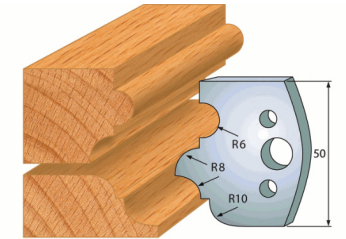

**Freesmes.**  
M520  
M5001

**Keermes**  
A520  
A5001

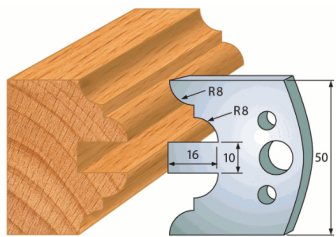

**Freesmes.**  
M522  
M5002

**Keermes**  
A522  
A5002

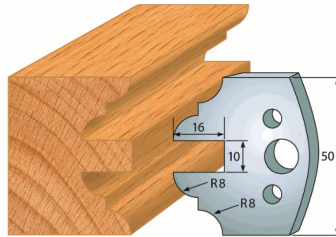

**Freesmes.**  
M523  
M5003

**Keermes**  
A523  
A5003

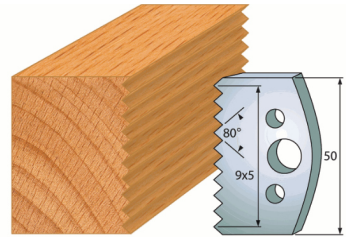

**Freesmes.**  
M524  
M5077

**Keermes**  
A524  
A5077

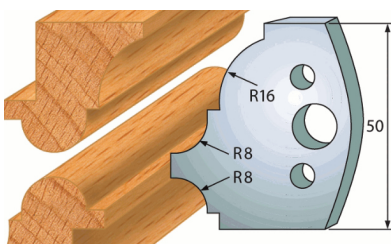

**Freesmes.**  
M541

**Keermes**  
A541

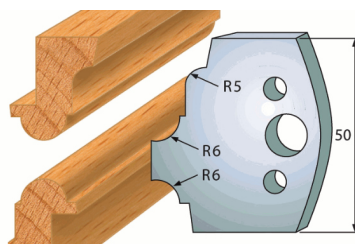

**Freesmes.**  
M542

**Keermes**  
A542

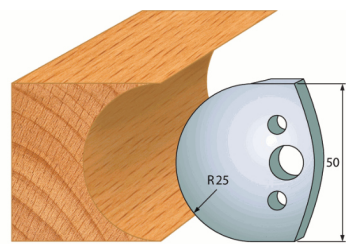

**Freesmes.**  
M543

**Keermes**  
A543

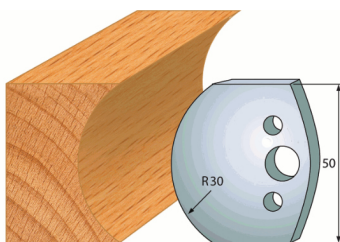

**Freesmes.**  
M544

**Keermes**  
A544

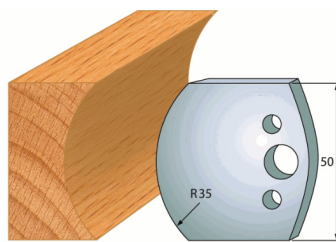

**Freesmes.**  
M545

**Keermes**  
A545

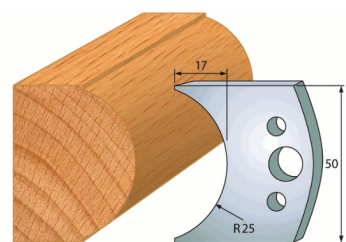

**Freesmes.**  
M546

**Keermes**  
A546



# Universeelmessen messen en keermessen 50x4

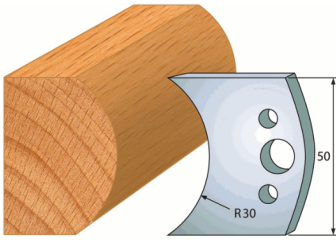

**Freesmes.**  
M547

**Keermes**  
A547

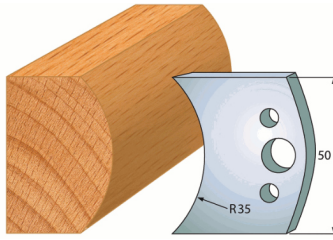

**Freesmes.**  
M548

**Keermes**  
A548

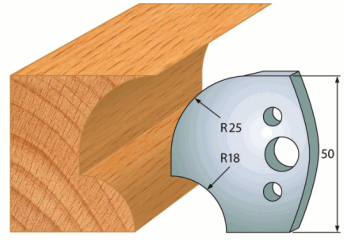

**Freesmes.**  
M549

**Keermes**  
A549

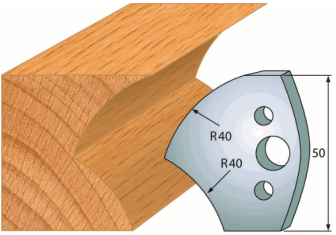

**Freesmes.**  
M550

**Keermes**  
A550

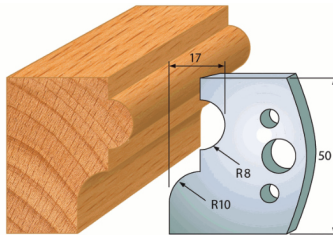

**Freesmes.**  
M551

**Keermes**  
A551

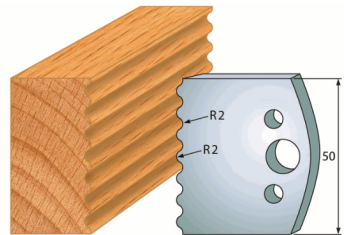

**Freesmes.**  
M552

**Keermes**  
A552

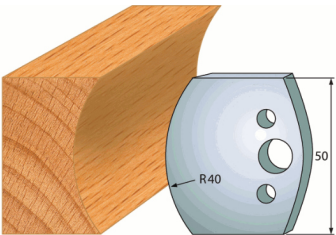

**Freesmes.**  
M553

**Keermes**  
A553

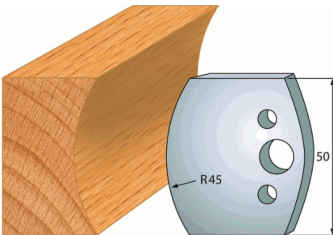

**Freesmes.**  
M554

**Keermes**  
A554

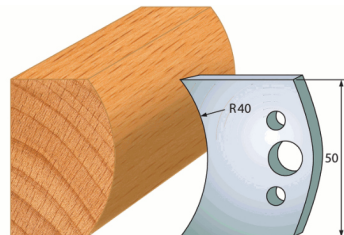

**Freesmes.**  
M555

**Keermes**  
A555

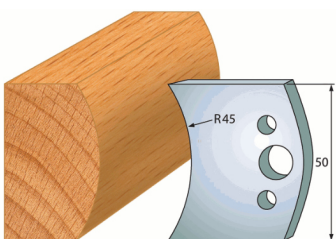

**Freesmes.**  
M556

**Keermes**  
A556

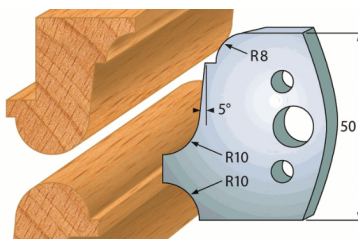

**Freesmes.**  
M557

**Keermes**  
A557

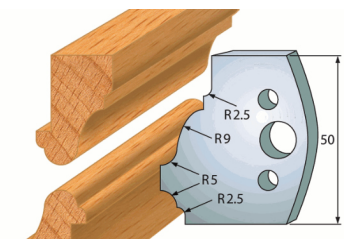

**Freesmes.**  
M558

**Keermes**  
A558

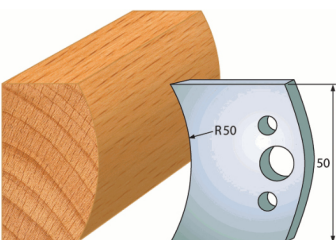

**Freesmes.**  
M559

**Keermes**  
A559

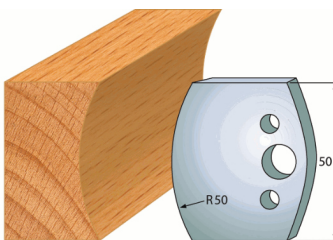

**Freesmes.**  
M560

**Keermes**  
A560

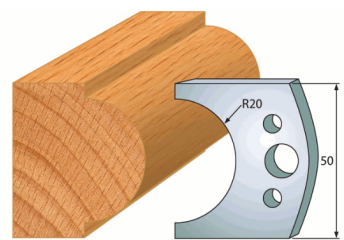

**Freesmes.**  
M561

**Keermes**  
A561

# Universeelmessen

## messen en keermessen 50x4

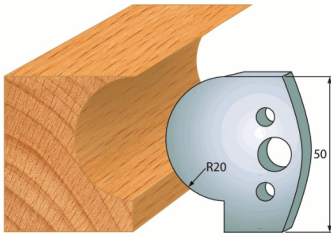

**Freesmes.**  
M562

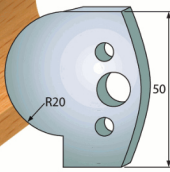

**Keermes**  
A562

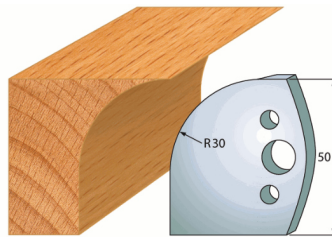

**Freesmes.**  
M563

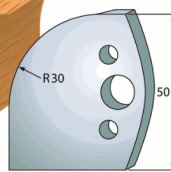

**Keermes**  
A563

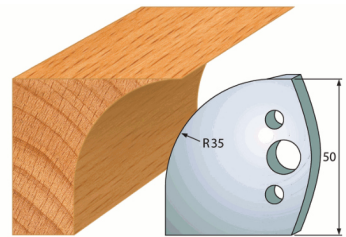

**Freesmes.**  
M564

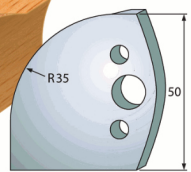

**Keermes**  
A564

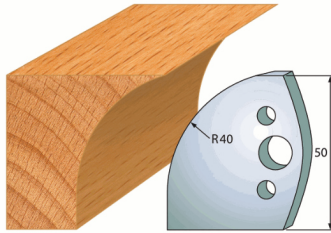

**Freesmes.**  
M565

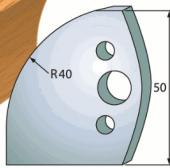

**Keermes**  
A565

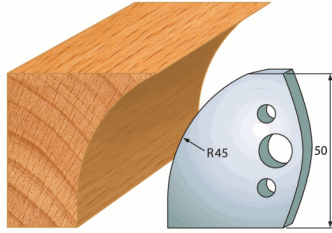

**Freesmes.**  
M566

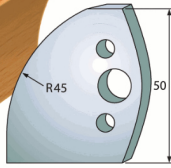

**Keermes**  
A566

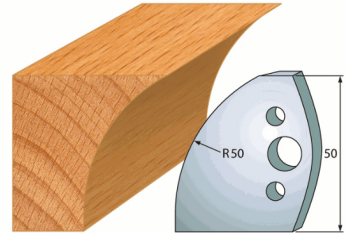

**Freesmes.**  
M567

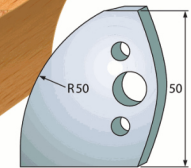

**Keermes**  
A567

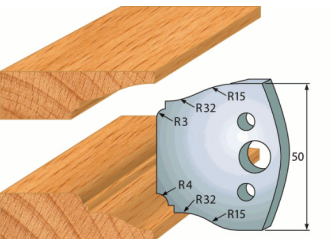

**Freesmes.**  
M568

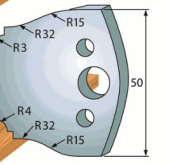

**Keermes**  
A568

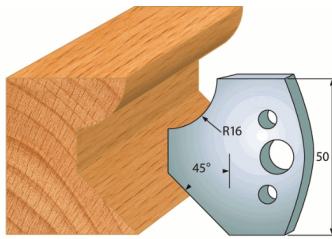

**Freesmes.**  
M569

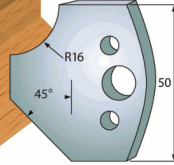

**Keermes**  
A569

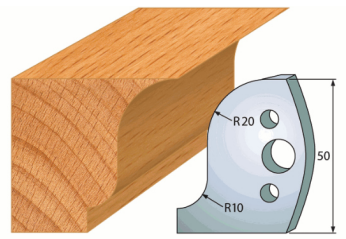

**Freesmes.**  
M570

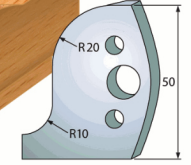

**Keermes**  
A570

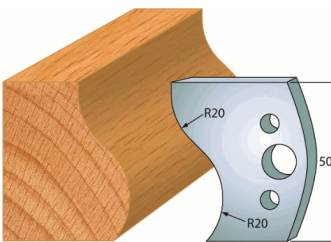

**Freesmes.**  
M571

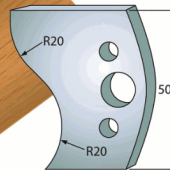

**Keermes**  
A571

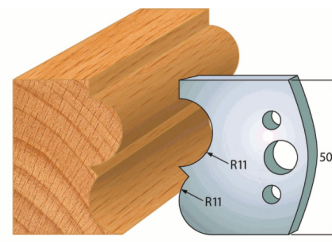

**Freesmes.**  
M572

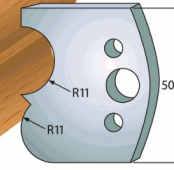

**Keermes**  
A572

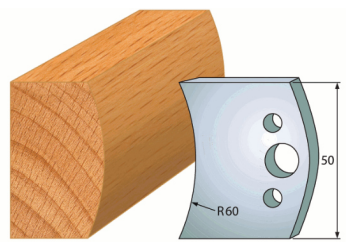

**Freesmes.**  
M573

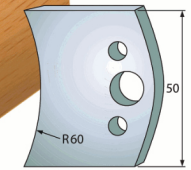

**Keermes**  
A573

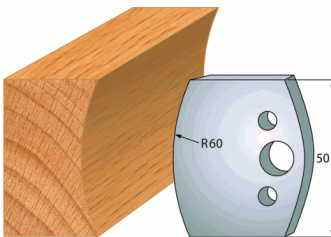

**Freesmes.**  
M574

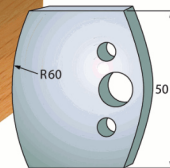

**Keermes**  
A574

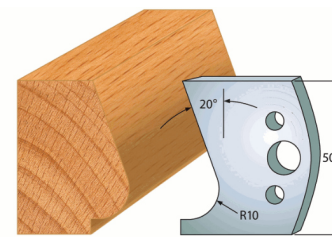

**Freesmes.**  
M575

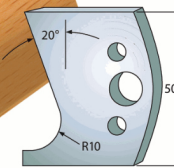

**Keermes**  
A575

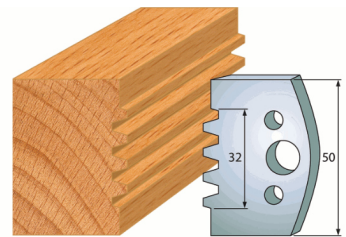

**Freesmes.**  
M576

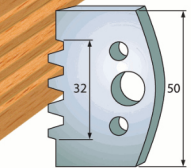

**Keermes**  
A576

# Universeelmessen messen en keermessen 50x4

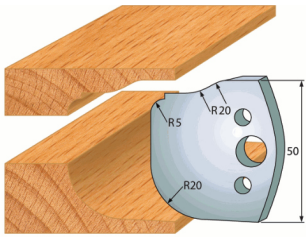

**Freesmes.**  
M577

**Keermes**  
A577

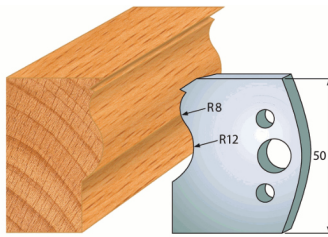

**Freesmes.**  
M578

**Keermes**  
A578

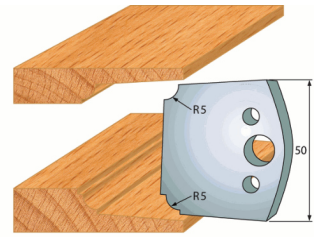

**Freesmes.**  
M579

**Keermes**  
A579

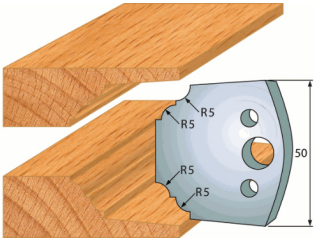

**Freesmes.**  
M580

**Keermes**  
A580

# Universeelmessen

## messen en keermessen 50x5,5

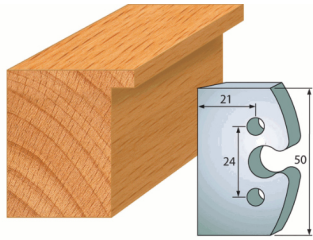

**Freesmes.**  
M200

**Keermes**  
A200

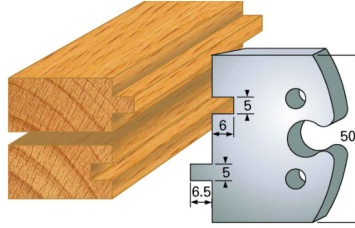

**Freesmes.**  
M201

**Keermes**  
A201

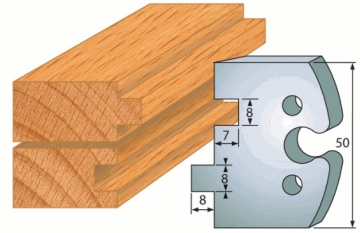

**Freesmes.**  
M202

**Keermes**  
A202

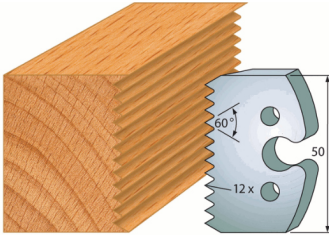

**Freesmes.**  
M203

**Keermes**  
A203

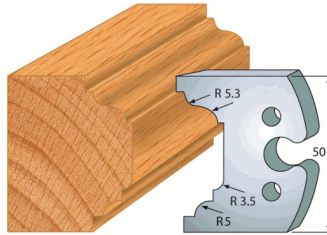

**Freesmes.**  
M204

**Keermes**  
A204

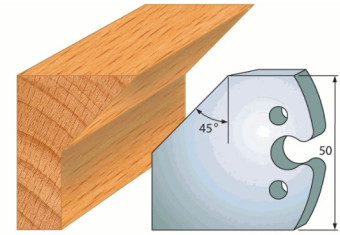

**Freesmes.**  
M205

**Keermes**  
A205

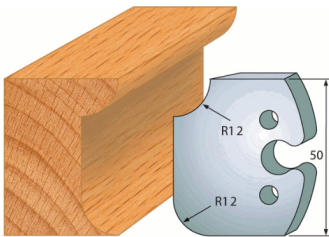

**Freesmes.**  
M206

**Keermes**  
A206

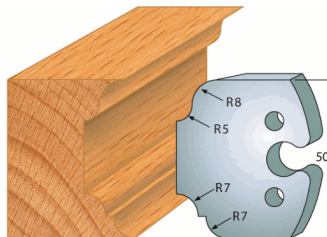

**Freesmes.**  
M207

**Keermes**  
A207

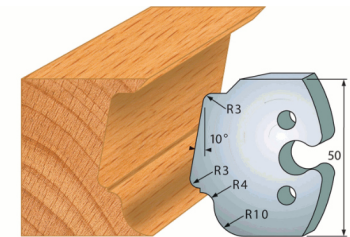

**Freesmes.**  
M208

**Keermes**  
A208

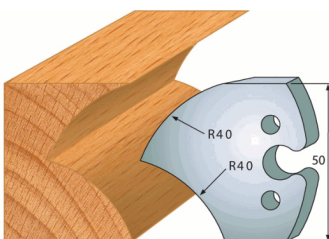

**Freesmes.**  
M209

**Keermes**  
A209

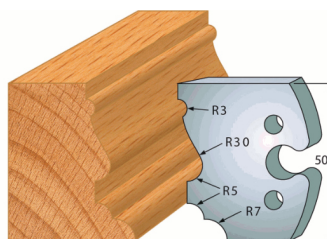

**Freesmes.**  
M210

**Keermes**  
A210

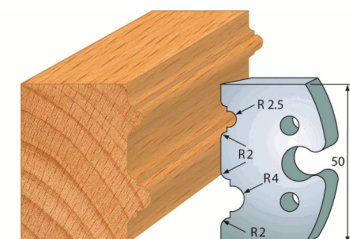

**Freesmes.**  
M211

**Keermes**  
A211

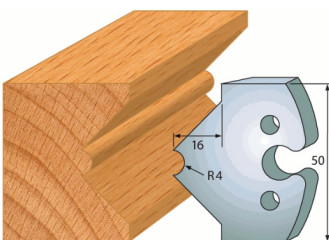

**Freesmes.**  
M212

**Keermes**  
A212

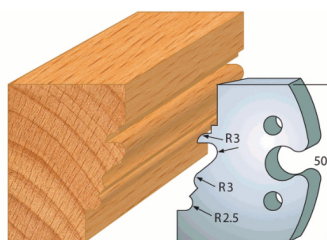

**Freesmes.**  
M213

**Keermes**  
A213

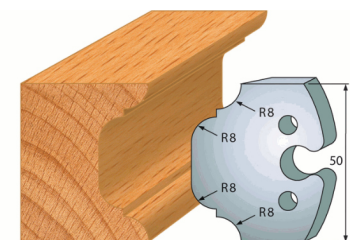

**Freesmes.**  
M214

**Keermes**  
A214

# Universeelmessen messen en keermessen 50x5,5

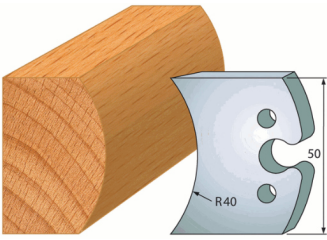

**Freesmes.**  
M215

**Keermes**  
A215

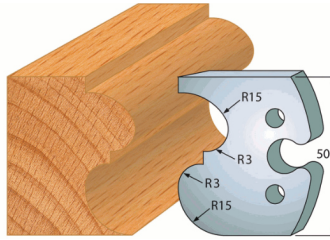

**Freesmes.**  
M216

**Keermes**  
A216

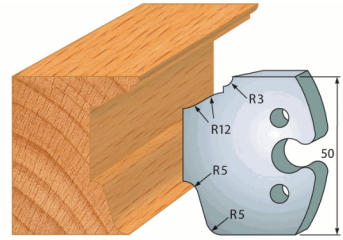

**Freesmes.**  
M217

**Keermes**  
A217

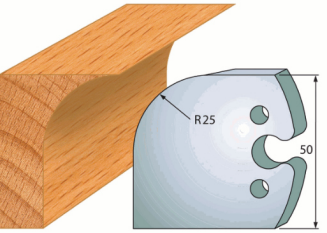

**Freesmes.**  
M218

**Keermes**  
A218

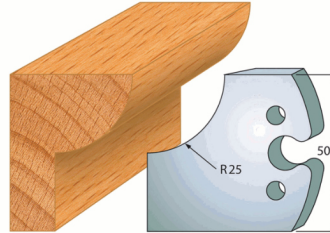

**Freesmes.**  
M219

**Keermes**  
A219

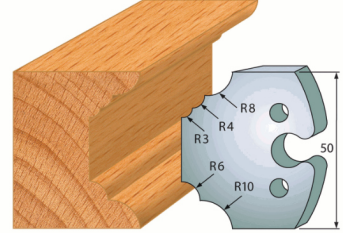

**Freesmes.**  
M220

**Keermes**  
A220

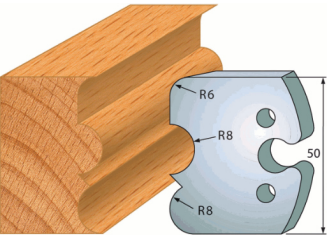

**Freesmes.**  
M221

**Keermes**  
A221

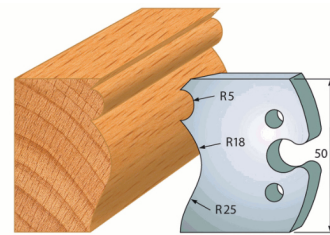

**Freesmes.**  
M222

**Keermes**  
A222

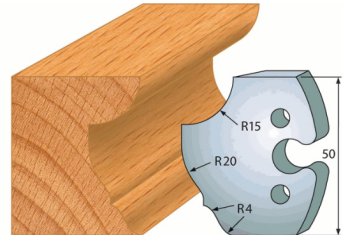

**Freesmes.**  
M223

**Keermes**  
A223

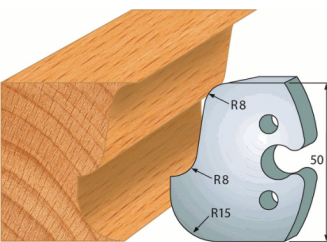

**Freesmes.**  
M224

**Keermes**  
A224

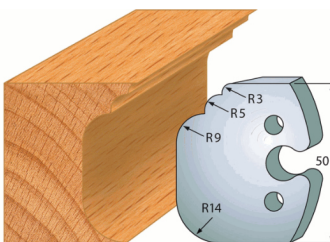

**Freesmes.**  
M225

**Keermes**  
A225

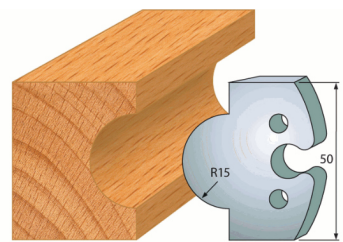

**Freesmes.**  
M226

**Keermes**  
A226

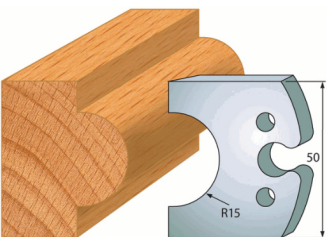

**Freesmes.**  
M227

**Keermes**  
A227

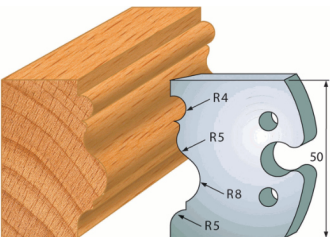

**Freesmes.**  
M228

**Keermes**  
A228

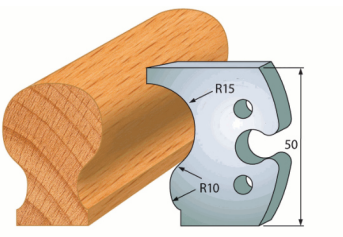

**Freesmes.**  
M229

**Keermes**  
A229

# Universeelmessen

## messen en keermessen 50x5,5

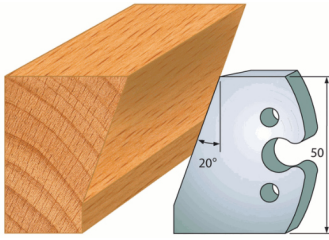

**Freesmes.**  
M230

**Keermes**  
A230

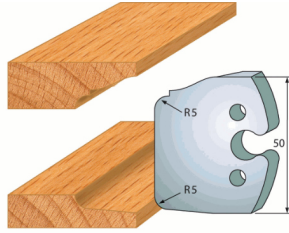

**Freesmes.**  
M231

**Keermes**  
A231

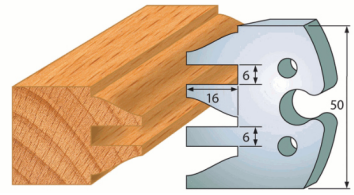

**Freesmes.**  
M232

**Keermes**  
A232

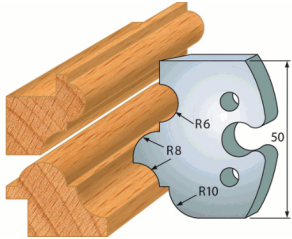

**Freesmes.**  
M233

**Keermes**  
A233

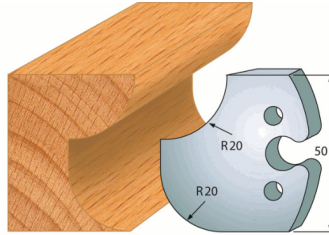

**Freesmes.**  
M238

**Keermes**  
A238

# Universeelmessen messen en keermessen 60x5,5

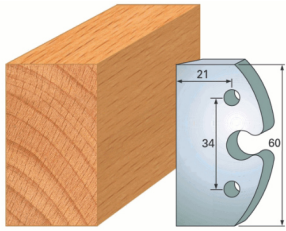

**Freesmes.**  
M6000

**Keermes**  
A6000

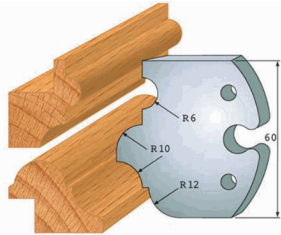

**Freesmes.**  
M6001

**Keermes**  
A6001

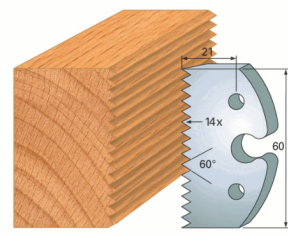

**Freesmes.**  
M6003

**Keermes**  
A6003

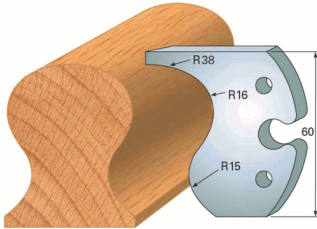

**Freesmes.**  
M6004

**Keermes**  
A6004

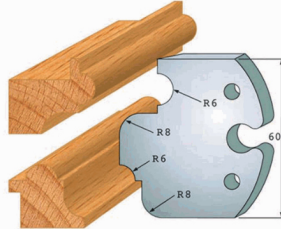

**Freesmes.**  
M6006

**Keermes**  
A6006

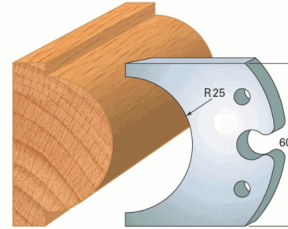

**Freesmes.**  
M6008

**Keermes**  
A6008

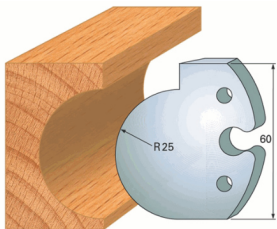

**Freesmes.**  
M6009

**Keermes**  
A6009

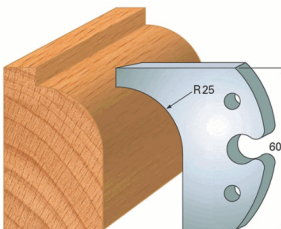

**Freesmes.**  
M6010

**Keermes**  
A6010

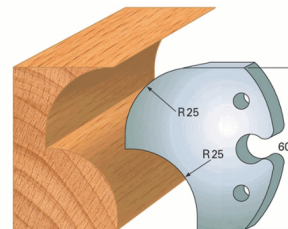

**Freesmes.**  
M6011

**Keermes**  
A6011

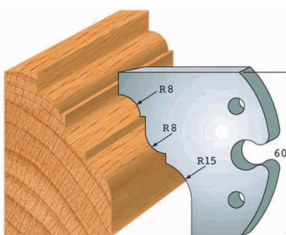

**Freesmes.**  
M6012

**Keermes**  
A6012

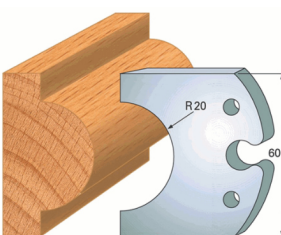

**Freesmes.**  
M6016

**Keermes**  
A6016

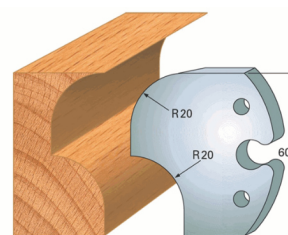

**Freesmes.**  
M6019

**Keermes**  
A6019

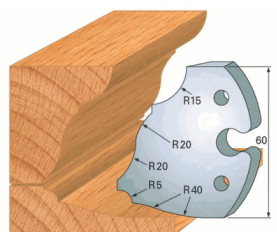

**Freesmes.**  
M6020

**Keermes**  
A6020

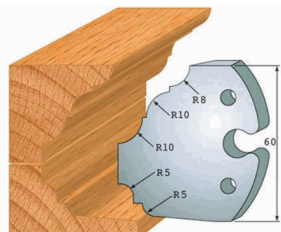



**Freesmes.**  
M6021

**Keermes**  
A6021

# Universeelmessen

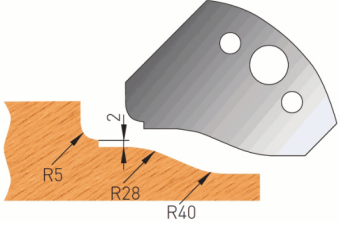
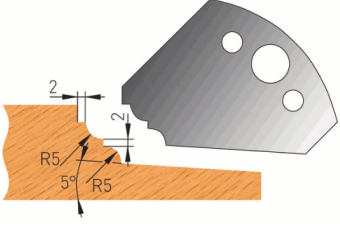
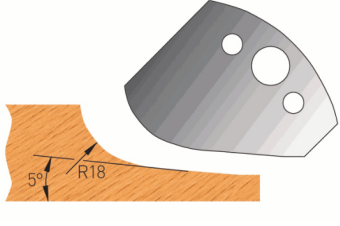
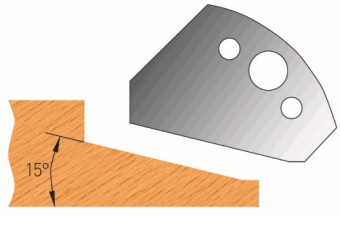
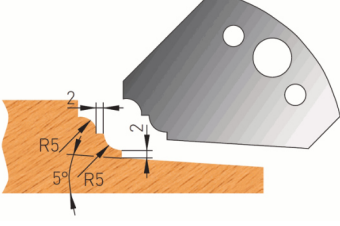
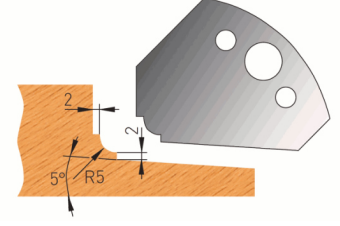
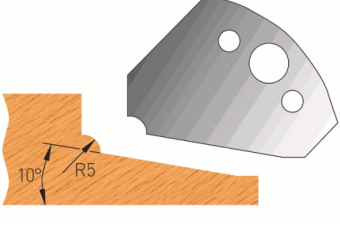
## Bossingmessen en keermessen 40x4

 <p><b>Freemess.</b> M700</p> <p><b>Keermes</b> A700</p>	 <p><b>Freemess.</b> M701</p> <p><b>Keermes</b> A701</p>	 <p><b>Freemess.</b> M702</p> <p><b>Keermes</b> A702</p>
 <p><b>Freemess.</b> M703</p> <p><b>Keermes</b> A703</p>	 <p><b>Freemess.</b> M704</p> <p><b>Keermes</b> A704</p>	 <p><b>Freemess.</b> M705</p> <p><b>Keermes</b> A705</p>
 <p><b>Freemess.</b> M706</p> <p><b>Keermes</b> A706</p>	 <p>Voor freeskop 3370 (zie pag 37)</p>	



# Universeelmessen messen en keermessen 59/64

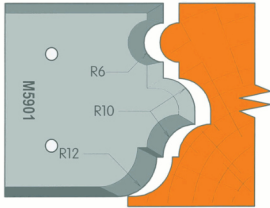

**Set 2+2 Messen en keermessen**  
M5901

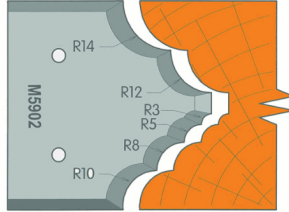

**Set 2+2 Messen en keermessen**  
M5902

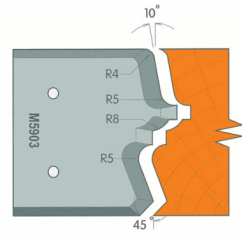

**Set 2+2 Messen en keermessen**  
M5903

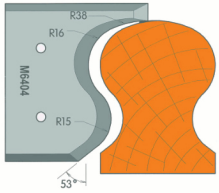

**Set 2+2 Messen en keermessen**  
M6404

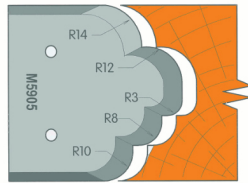

**Set 2+2 Messen en keermessen**  
M5905

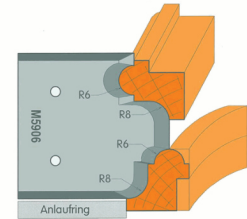

**Set 2+2 Messen en keermessen**  
M5906

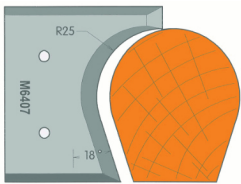

**Set 2+2 Messen en keermessen**  
M6407

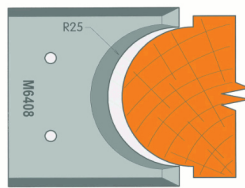

**Set 2+2 Messen en keermessen**  
M6408

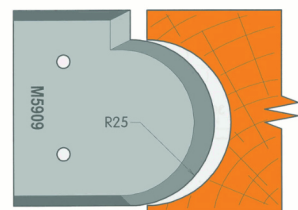

**Set 2+2 Messen en keermessen**  
M5909

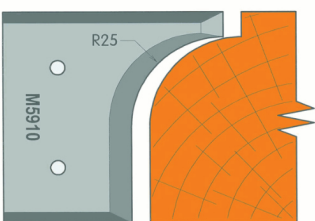

**Set 2+2 Messen en keermessen**  
M5910

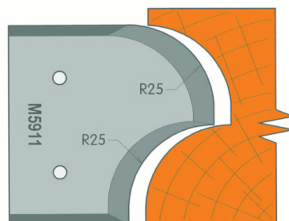

**Set 2+2 Messen en keermessen**  
M5911

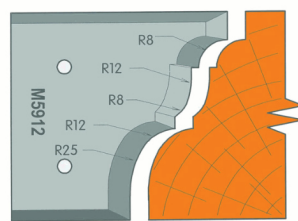

**Set 2+2 Messen en keermessen**  
M5912

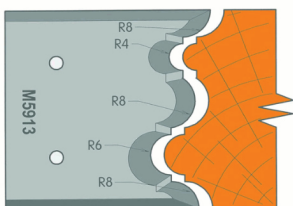

**Set 2+2 Messen en keermessen**  
M5913

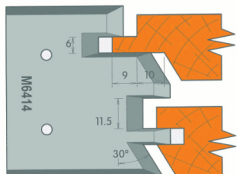

**Set 2+2 Messen en keermessen**  
M6414

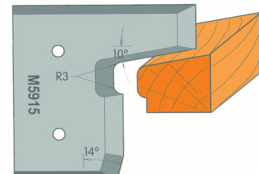

**Set 2+2 Messen en keermessen**  
M5915

# Universeelmessen

## messen en keermessen 59/64

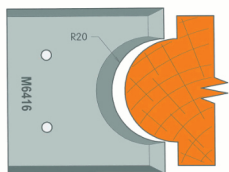

**Set 2+2 Messen en keermessen**  
M6416

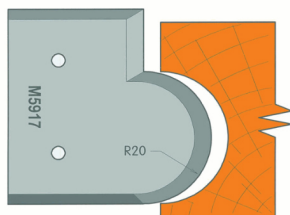

**Set 2+2 Messen en keermessen**  
M5917

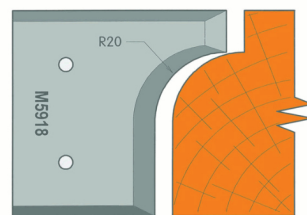

**Set 2+2 Messen en keermessen**  
M5918

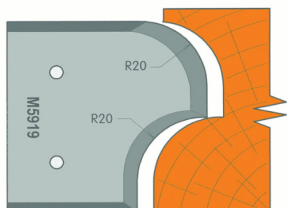

**Set 2+2 Messen en keermessen**  
M5919

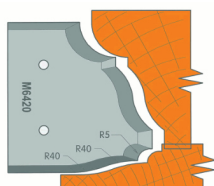

**Set 2+2 Messen en keermessen**  
M6420

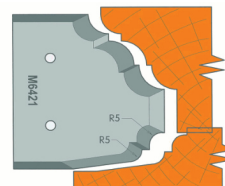

**Set 2+2 Messen en keermessen**  
M6421

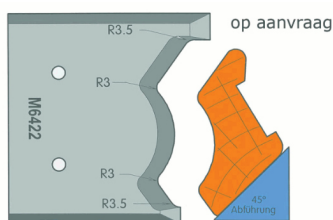

**Set 2+2 Messen en keermessen**  
M6422

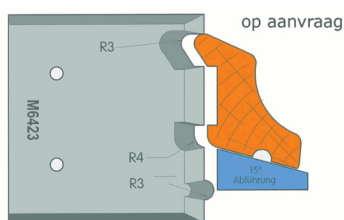

**Set 2+2 Messen en keermessen**  
M6423

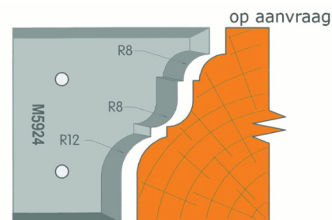

**Set 2+2 Messen en keermessen**  
M5924

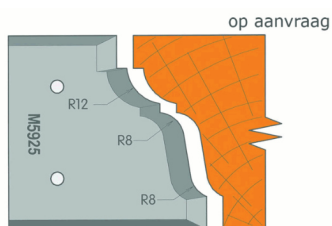

**Set 2+2 Messen en keermessen**  
M5925

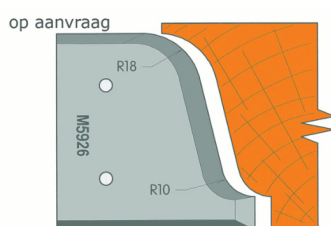

**Set 2+2 Messen en keermessen**  
M5926

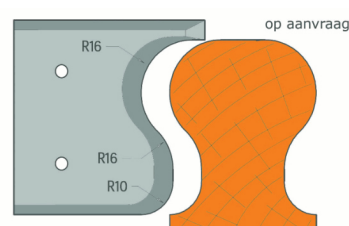

**Set 2+2 Messen en keermessen**  
M5927

# Universeelmessen blanketten

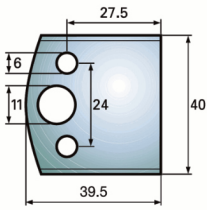

**Freesmes.**  
M4040HSS

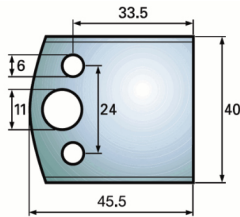

**Freesmes.**  
M4045HSS

**Keemes**  
ABLANKET  
MBLANKET SP

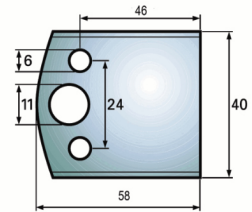

**Freesmes.**  
M4058HSS

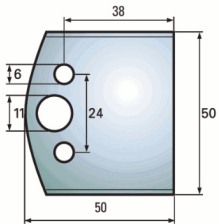

**Freesmes.**  
M5050HSS

**Keemes**  
A5050

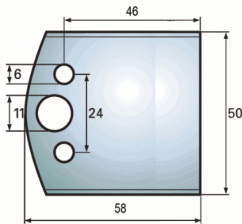

**Freesmes.**  
M5058HSS

**Keemes**  
A5058

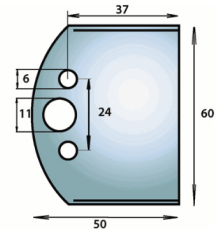

**Freesmes.**  
M6050HSS

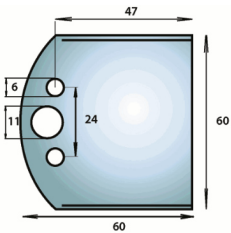

**Freesmes.**  
M6060HSS

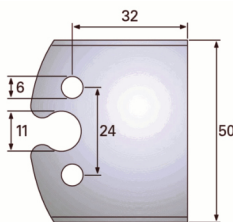

**Freesmes.**  
M5032-55

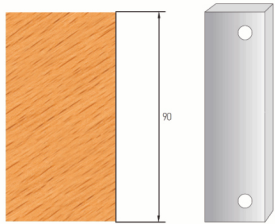

**Freesmes.**  
M590.399



**Keemes**  
A590.399

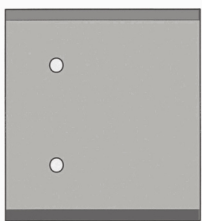

**Freesmes.**  
M5999

**Keemes**  
A5999

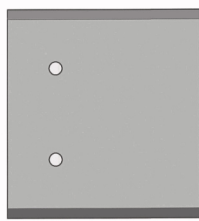

**Freesmes.**  
M6499

**Keemes**  
A6499





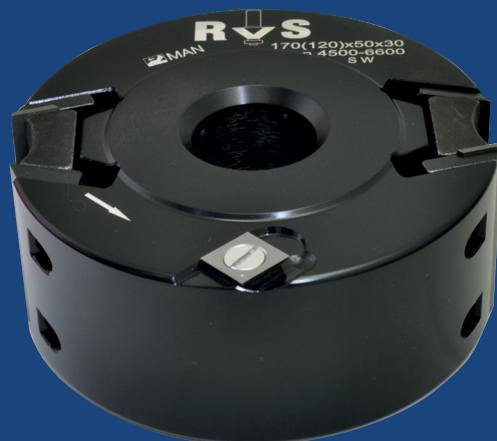

**RvS**  
**TOOLS**

RvS Tools B.V.  
Meridaan 53  
2801 DA Gouda  
+31 182 338 444

[info@rvsemail.com](mailto:info@rvsemail.com)  
[www.rvstools.eu](http://www.rvstools.eu)

